

**Booster
Systems**



 **calpeda[®]**

CE

Selecting the right booster

Two parameters need to be determined for choosing the right booster for any application. These parameters are maximum volume of flow and the pressure head required for the specific application.

After these parameters are determined, some requested properties such as provision for a spare / stand-by pump, predetermined operation scenario of pumps if any etc. are considered to choose the right booster series from the available booster types, having the correct capacity.

Calculating volume of flow in apartments

In buildings used as general living areas, we need to know three factors to calculate the volume of flow correctly.

These factors are:

- Number of armatures in the building
- Consumption rates for each type of armature (Given in table below)
- Factor of simultaneous use (Fc)

Consumption rates for armature types

Armature	Flow (l/min)
Washbasin	10
Bathtub	10
Jakuzzi	18
Shower	12
WC with reservoir	7
WC without reservoir	90
Bidet	6
Laundry machine	12
Kitchen sink	12
Dish washer	8
1/2" tap	20
3/4" tap	25

It is obviously possible to calculate the theoretical maximum rate of consumption in a building by multiplying the number of armatures in the building by their consumption rates.

But in practice, we need a statistical value for simultaneous use of armatures, since all of the armatures are not used simultaneously most of the time.

Factor of simultaneous use may be calculated by using the following equations.

The Ut value in the equations is the total number of armatures in the building.

Houses with one reservoir type bathroom

$$F_c = \frac{1}{\sqrt{0.85 \times U_t}}$$

Houses with one non-reservoir type bathroom

$$F_c = \frac{1}{\sqrt{0.7 \times U_t}}$$

Houses with two reservoir type bathrooms

$$F_c = \frac{1}{\sqrt{1.1 \times U_t}}$$

Houses with two non-reservoir type bathrooms

$$F_c = \frac{1}{\sqrt{0.83 \times U_t}}$$

The next diagram shows the maximum volumes of flow in relation to number of houses and type of bathrooms in building.

This diagram is prepared considering seven armatures in single bathroom houses, and ten armatures in two bathroom houses.

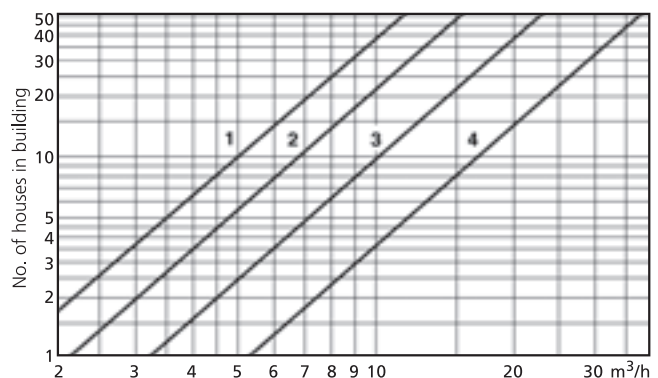

- 1 Houses with one reservoir type bathroom
- 2 Houses with one non-reservoir type bathroom
- 3 Houses with two reservoir type bathrooms
- 4 Houses with two non-reservoir type bathrooms

Calculating volume of flow in commercial buildings

The diagram below shows the demand rate in commercial building types in relation to number of people in the buildings. Even though it is possible to use these values as a guide, it is advised to evaluate them in accordance with application requirements.

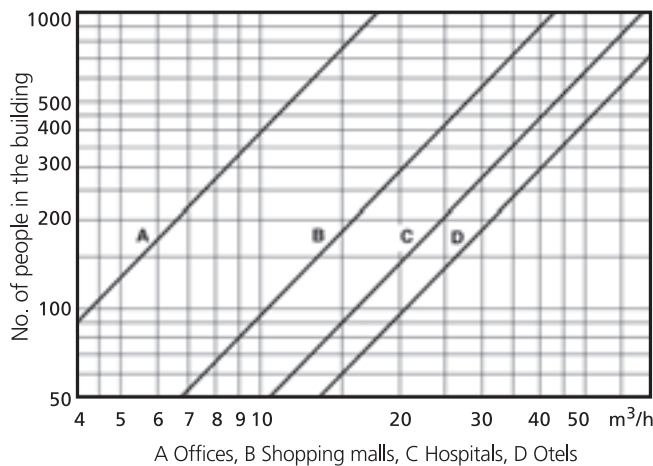

Determining pressure head of booster

For a trouble free operation of electrical household equipment like dishwashers or laundry machines, the minimum water pressure at point of use is required to be 1 bar, and maximum 3-4 bars.

If an electrical equipment has operational problems resulting from inadequate water pressure, use of a pressure booster is necessary to provide the required pressure.

The parameters need to be considered for calculating the pressure head of a booster are given below:

- H_g The height from the booster installation area to the highest point of water use in the building
- H_a Suction head for boosters operating in suction lift conditions
- P_i Pump inlet pressure
- P_r Desired water pressure at the topmost water use point (Usually 1-1.5 bars)
- P_c Total friction losses in the system
- Δp The difference between cut-in and cut-out pressures of the pump

If the pumps operate under suction lift conditions, the suction height is advised to be not more than 4 meters. Suction heights more than that or a suction piping not strictly conforming to suction line requirements may render faulty operation of the pump or pump damages may probably occur. The best practise is to avoid running the pumps under suction lift conditions.

For an approximate calculation of friction losses in the system, 1 mWC per floor level for old buildings, and 0.5 mWC per floor level for new buildings may be used.

Especially in buildings higher than 25-30 meters (8-10 levels), it is impossible to avoid pressure rises above 4-5 bars at lower levels. To overcome this situation, either the supply lines of lower levels must be separated from the supply lines of upper levels, and supplied through a pressure reducer; or use of a separate booster for lower and upper levels must be considered.

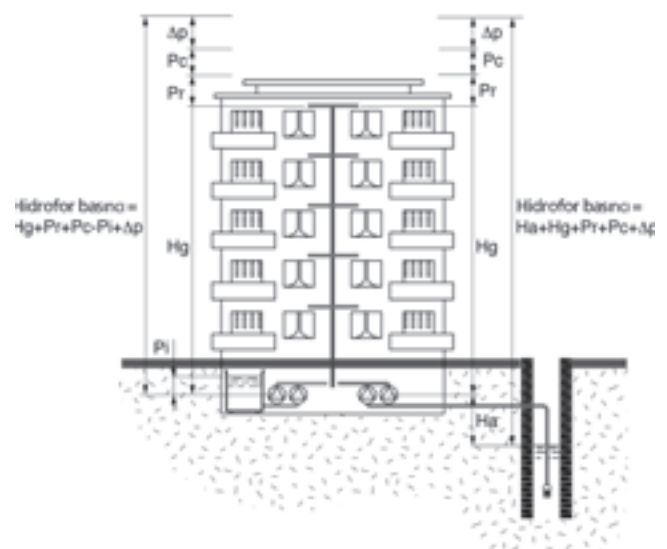

Friction Losses in Piping

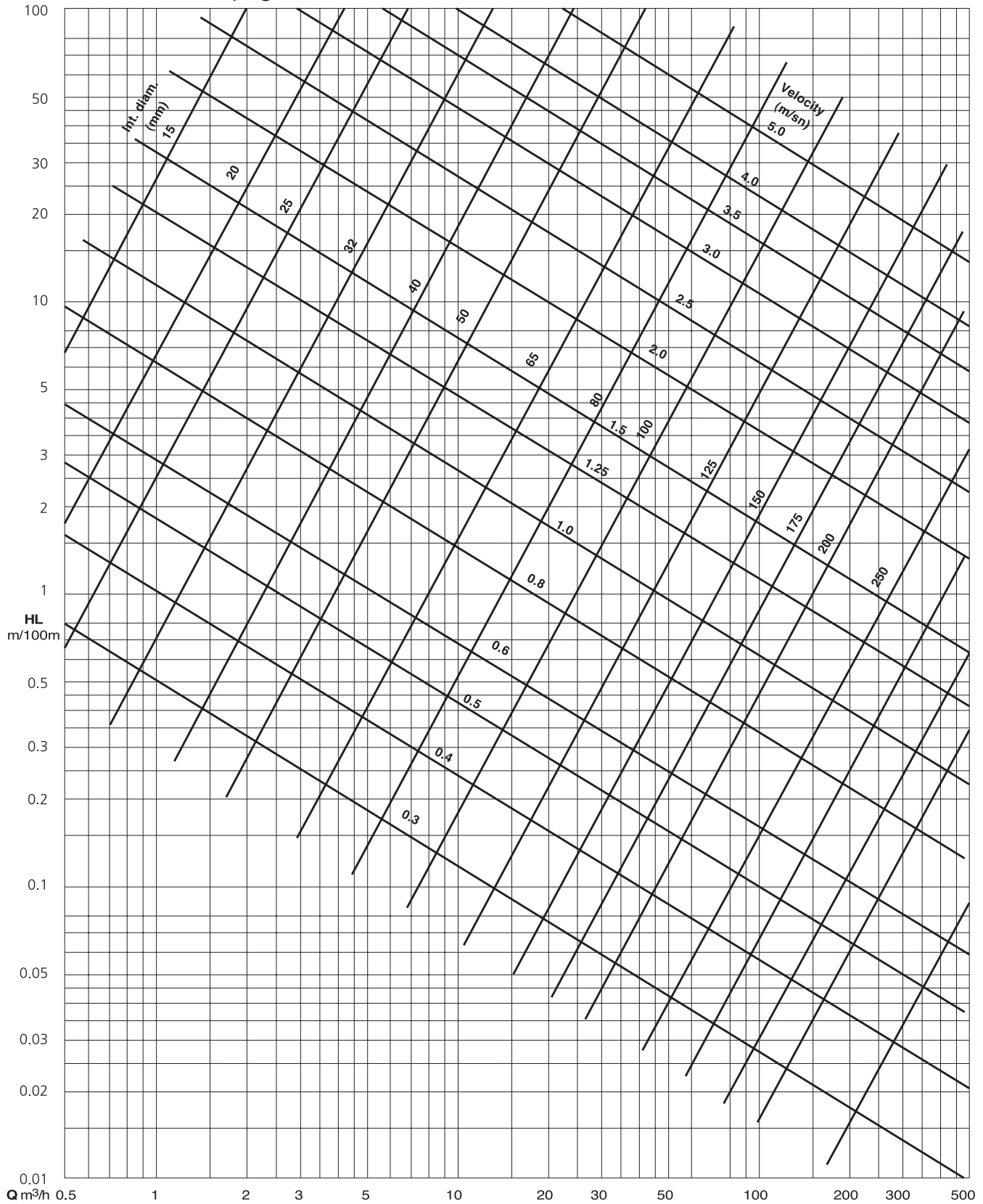

Friction Losses in Piping

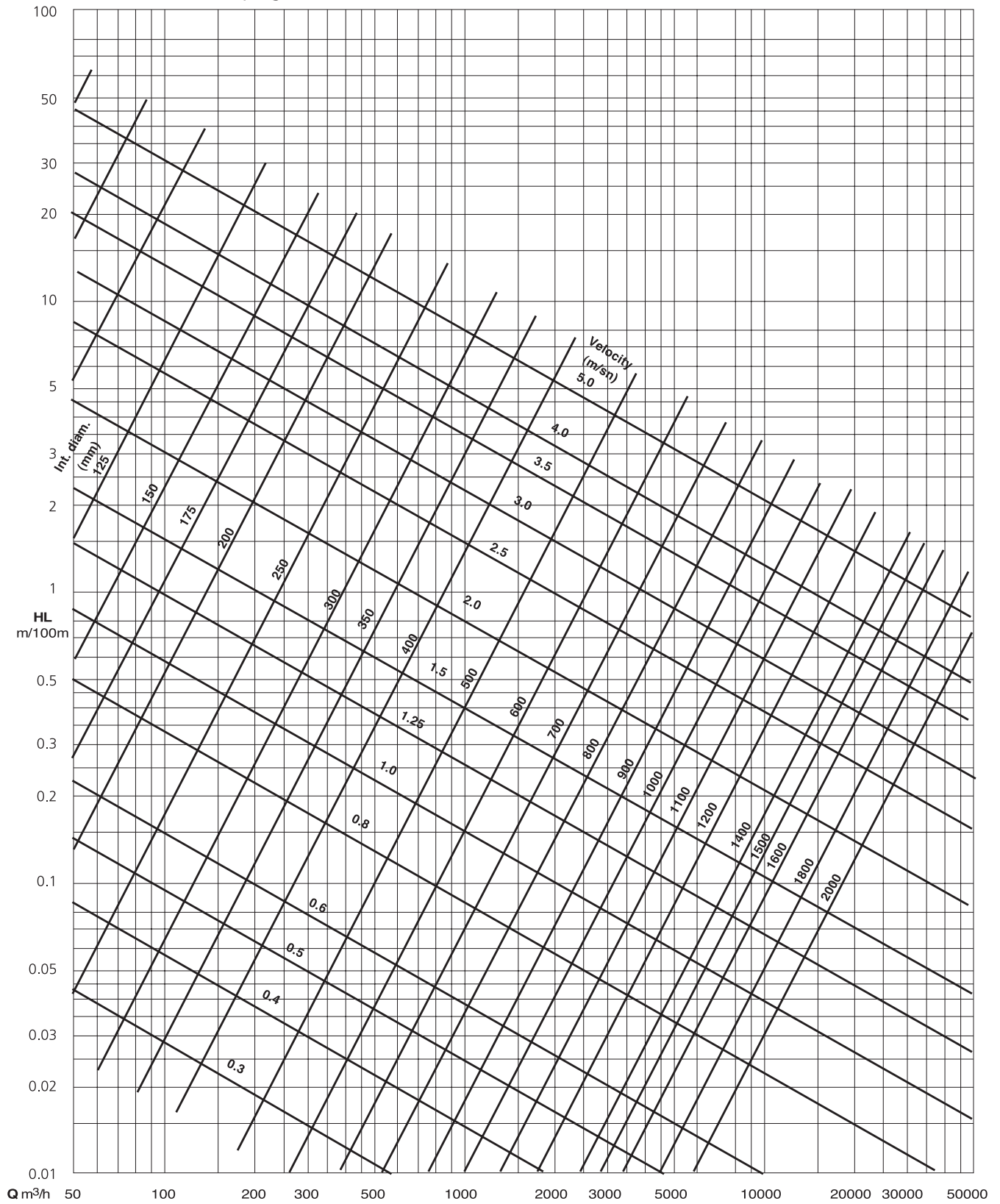

Construction

Pressure boosting sets with automatic operation, consisting of 2 pumps on a common baseplate, with suction and delivery manifolds, isolation and non-return valves, pressure switches, pressure gauge and control panel. Suction and delivery manifolds are in AISI304 stainless steel. The unit includes one pressure gauge and two adjustable differential pressure switch.

Operation

According to the pressure decrease in the system, the control panel with electronic card, manages the pump operation, the change over of pump starting sequence and it stops the system when there is no water in the tank. Pumps starting in a cascade sequence, with a signal from the pressure switches. New electrical control panels for pressurization units, all with electronic card with microprocessor carries out continuous secure checks during all the various work phases of the pumps and incorporates all necessary functions, thus reducing electrical and electronic components inside the panel.

In particular;

- Pumps starting in a cascade sequence according to water demand
- Changeover of pump starting sequence
- Pumps stop when there is no water in the suctions

Maximum clarity for all signals

The status of the units can easily be identified on the front of the electronic card with the following signals;

- Power on led - Failure led (1 for each pump)
- No water led - Pump running led (1 for each pump)

Maximum simplicity of control.

The front of electronic card features the following signals and controls;

- AUT-STOP-MAN button (1 for each pump)
- RESET push-button

Applications

- Water supply
- Sprinkling
- Irrigation and spraying
- Pumping water from wells and out of low-lying tanks.



Technical Data

- Mains connections 1~230V/50 Hz/3~400V/50 Hz
- Suction head max 8 m
- Inlet pressure max 4 bar
- Fluid temperature +5 °C to +40 °C
- Operating pressure max 10 bar
- Pressure switch setting range 1-6.5 bar
- Protection class IP54

Motors

2-pole induction motors, 50 Hz, n=2900 rpm
Single-phase 230V ± %10, with thermal protector
Three-phase 230/400V ± %10
Insulation class F
Protection IP54
Constructed in accordance with IEC 60034
Other voltages and frequencies on request.

		Q (m ³ /h)								
		0	1	2	3	4	5	6	7	
MXHM 202 E	H (m)	0	20	18	14	10				
MXHM 203 E		0	32	27	22	15				
MXHM 204/A		0	42	37	31	22				
MXHM 205/A		0	53	47	38	28				
MXHM 206		0	65	57	48	36				
MXHM 402E					20	18	17	15	12	9
MXHM 403/A					30	28	26	23	20	15
MXHM 404/A					42	38	35	32	26	20
MXHM 405					52	50	45	40	34	27
MXHM 406					64	61	56	50	44	34

		Q (m ³ /h)							
		0	4	6	8	10	12		
MXHM 802/A	H (m)			20	18	15	12		
MXHM 803				32	27	23	17		
MXHM 804				42	37	32	23		
MXH 805/A				54	47	40	30		

		Q (m ³ /h)							
		0	8	12	16	20	24		
MXH 1602	H (m)		22	20	17	14	8		
MXH 1603/A			32	28	25	19	12		
MXH 1604/A			42	40	35	28	17		
MXH 1605/A			54	50	45	36	22		
MXH 1606/A			65	60	54	43	27		

		Q (m ³ /h)							
		0	10	20	30	40	50		
MXH 3202/A	H (m)			32	27	19	7		
MXH 3203/A				44	41	30	10		
MXH 3204/A				64	57	42	18		

		Q (m ³ /h)							
		20	30	40	50	60			
MXH 4802/A	H (m)	36	32	28	22	12			
MXH 4803/A		58	54	42	33	22			

		Q (m ³ /h)							
		0	1	2	3	4			
NGXM 2	H (m)	0	35	25					
NGXM 3/A		0	38	33					
NGXM 4/A		0	37	32	27	23			

		Q (m ³ /h)							
		0	1	2	3				
ASPRI 15 3 M	H (m)	0	29	25	17				
ASPRI 15 4 M		0	40	33	22				
ASPRI 15 5 M		0	47	38	27				

		Q (m ³ /h)							
		0	1	2	3	4	5	6	
ASPRI 25 3 M	H (m)	0	34	32	30	27	24	18	
ASPRI 25 4 M		0	43	41	39	35	30	24	
ASPRI 25 5 M		0	57	55	52	47	38	32	

		Q (m ³ /h)							
		0	1	2	3	4	5	6	7
MXPM 202	H (m)	0	18	16	12	8			
MXPM 203		0	28	25	20	14	8		
MXPM 204/A		0	40	35	28	22	13		
MXPM 402					18	15	13	9	6
MXPM 403/A					27	25	22	17	12
MXPM 404/A		0		42	38	33	28	23	17

		Q (m ³ /h)								
		0	1	2	3	4	5	6	7	8
PRISMA 35 4 M	H (m)	0	54	52	50	48	46	38	34	28
PRISMA 35 5 M		0	67	64	62	58	54	48	42	36
PRISMA 35 6 T		0	79	78	76	72	66	60	52	44

		Q (m ³ /h)							
		0	2	4	6	8	10	12	14
PRISMA 45 4 T	H (m)	0	48	44	42	38	32	23	14
PRISMA 45 5 T		0	60	58	53	48	40	30	20

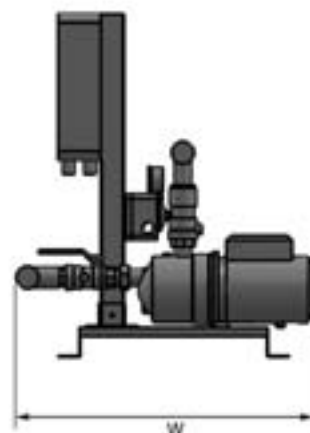
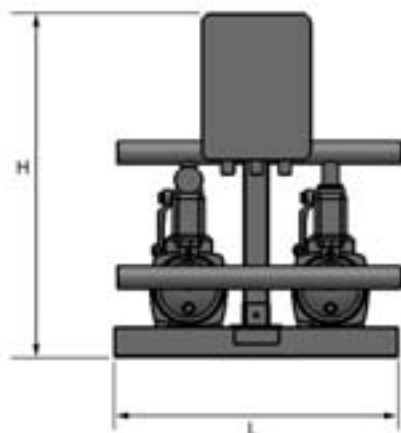

Model	DNs	DNd	W	L	H
DCM2 - MXHM 202 E	1½"	1½"	600	600	760
DCM2 - MXHM 203 E	1½"	1½"	600	600	760
DCM2 - MXHM 204/A	1½"	1½"	600	650	760
DCM2 - MXHM 205/A	1½"	1½"	600	650	760
DCM2 - MXHM 206	1½"	1½"	600	680	760
DCM2 - MXHM 402E	2"	1½"	600	680	760
DCM2 - MXHM 403/A	2"	1½"	600	680	760
DCM2 - MXHM 404/A	2"	1½"	600	680	760
DCM2 - MXHM 405	2"	1½"	600	680	760
DCM2 - MXHM 406	2"	1½"	600	680	760
DCM2 - MXHM 802/A	1½"	1"	600	700	760
DCM2 - MXHM 803	1½"	1"	600	700	760
DCM2 - MXHM 804	1½"	1"	600	700	760
DC2 - MXH 805/A	1½"	1"	600	700	760
DC2 - MXH 1602	3"	2"	800	1150	1050
DC2 - MXH 1603/A	3"	2"	800	1150	1050
DC2 - MXH 1604/A	3"	2"	800	1150	1050
DC2 - MXH 1605/A	3"	2"	800	1150	1050
DC2 - MXH 1606/A	3"	2"	800	1150	1050
DC2 - MXH 3202/A	DN100	DN80	800	1150	1050
DC2 - MXH 3203/A	DN100	DN80	800	1150	1050
DC2 - MXH 3204/A	DN100	DN80	800	1150	1050
DC2 - MXH 4802/A	DN125	DN100	800	1150	1050
DC2 - MXH 4803/A	DN125	DN100	800	1150	1050
DCM2 - NGXM 2	1½"	1½"	600	600	760
DCM2 - NGXM 3/A	1½"	1½"	600	600	760
DCM2 - NGXM 4/A	1½"	1½"	600	600	760
DCM2 - ASPRI 15 3 M	1½"	1½"	600	600	760
DCM2 - ASPRI 15 4 M	1½"	1½"	600	600	760
DCM2 - ASPRI 15 5 M	1½"	1½"	600	600	760
DCM2 - ASPRI 25 3 M	1½"	1½"	600	600	760
DCM2 - ASPRI 25 4 M	1½"	1½"	600	600	760
DCM2 - ASPRI 25 5 M	1½"	1½"	600	600	760
DCM2 - MXPM 202	1½"	1½"	600	600	760
DCM2 - MXPM 203	1½"	1½"	600	600	760
DCM2 - MXPM 204/A	1½"	1½"	600	600	760
DCM2 - MXPM 402	1½"	1½"	600	600	760
DCM2 - MXPM 403/A	1½"	1½"	600	600	760
DCM2 - MXPM 404/A	1½"	1½"	600	600	760
DCM2 - PRISMA 35 4 M	2"	1½"	600	800	760
DCM2 - PRISMA 35 5 M	2"	1½"	600	800	760
DC2 - PRISMA 35 6 T	2"	2"	600	800	760
DC2 - PRISMA 45 4 T	2"	2"	600	800	760
DC2 - PRISMA 45 5 T	2"	2"	600	800	760

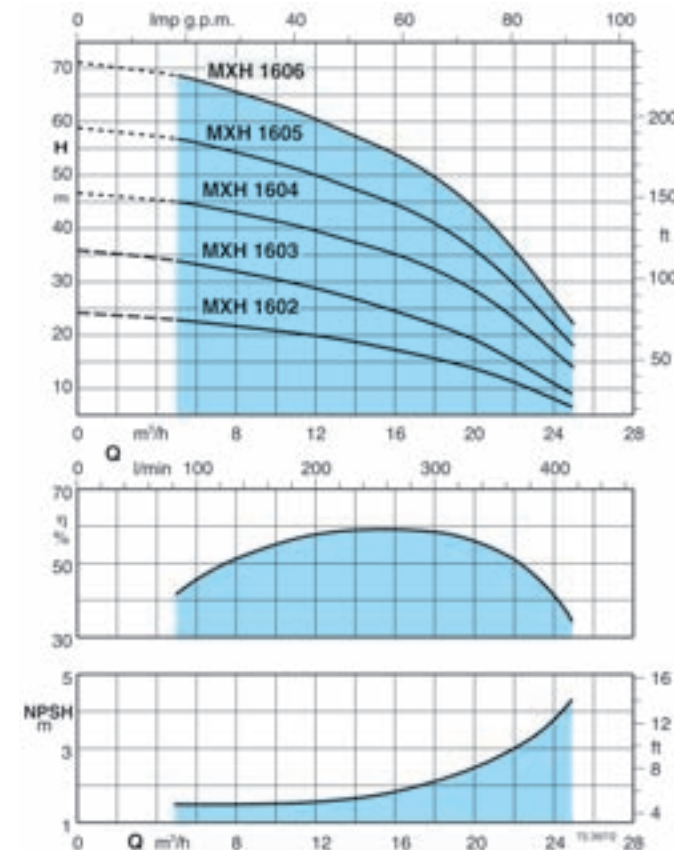
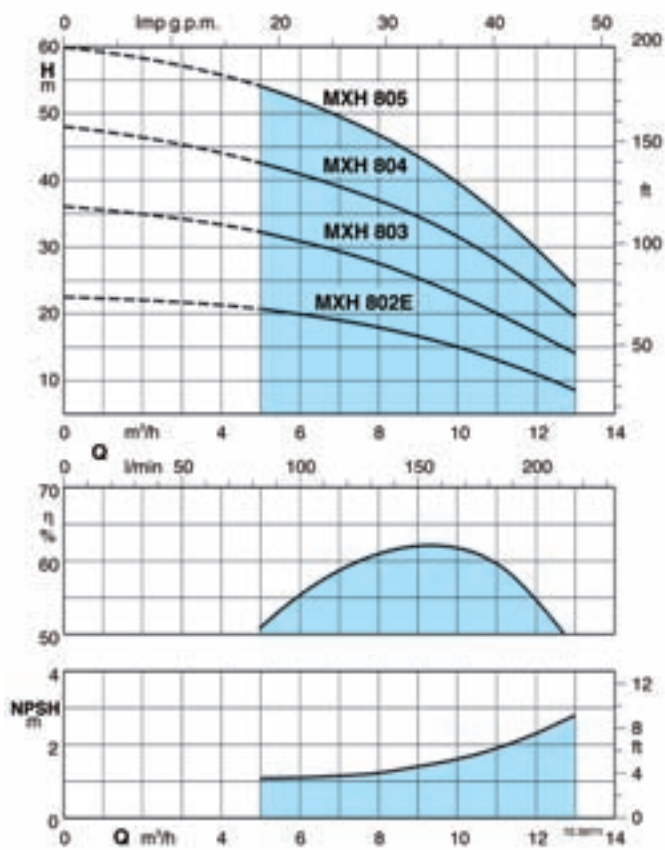
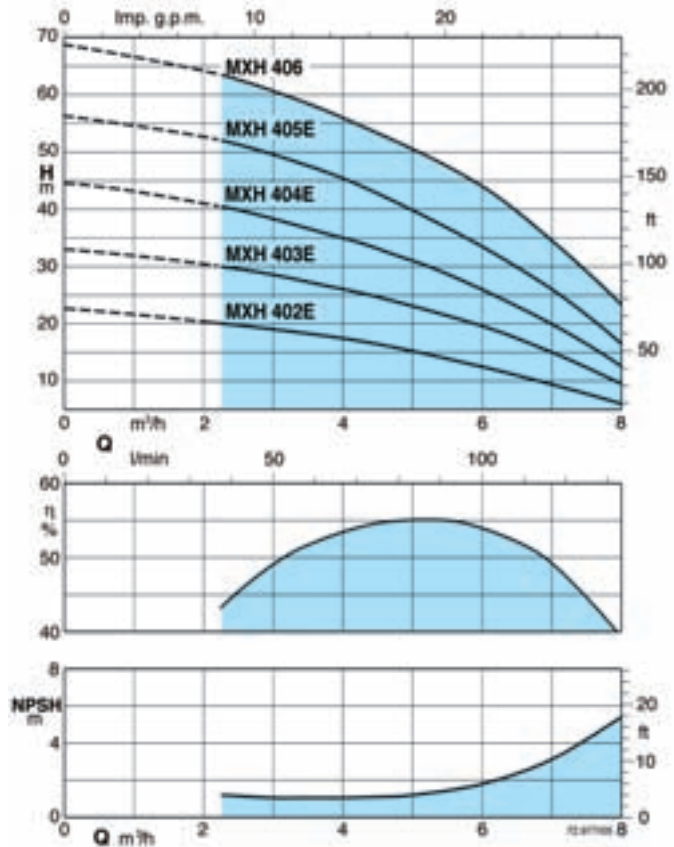
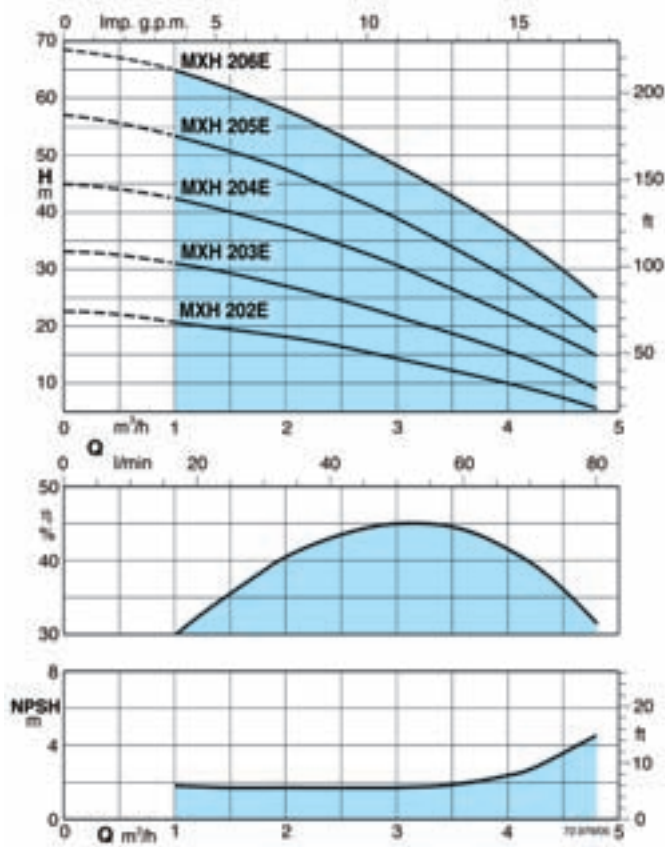

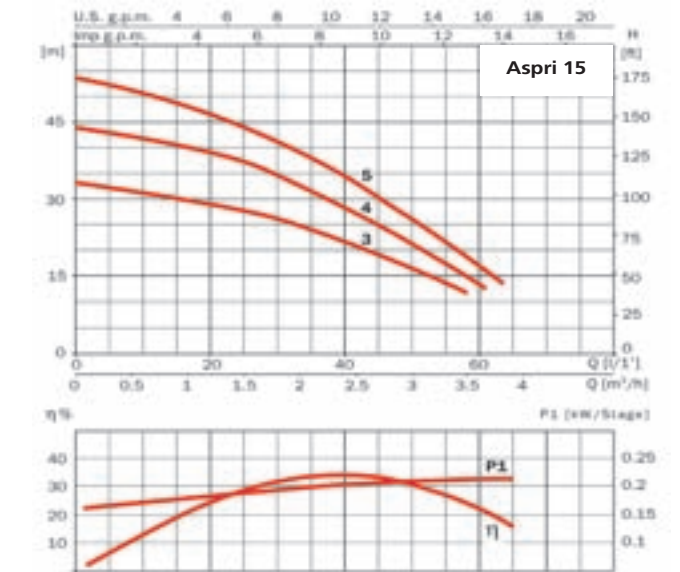
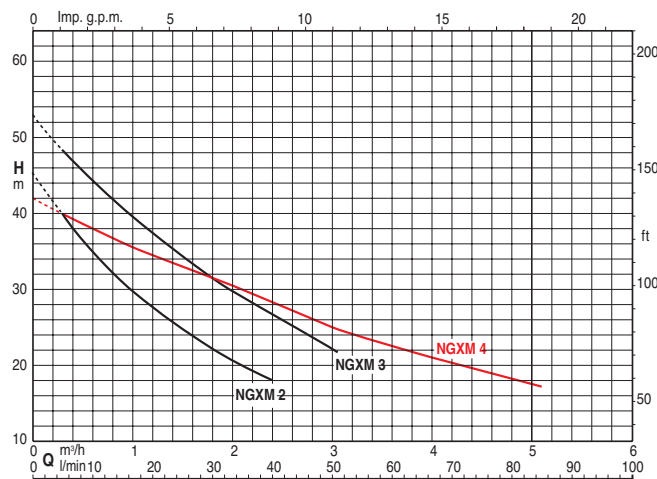
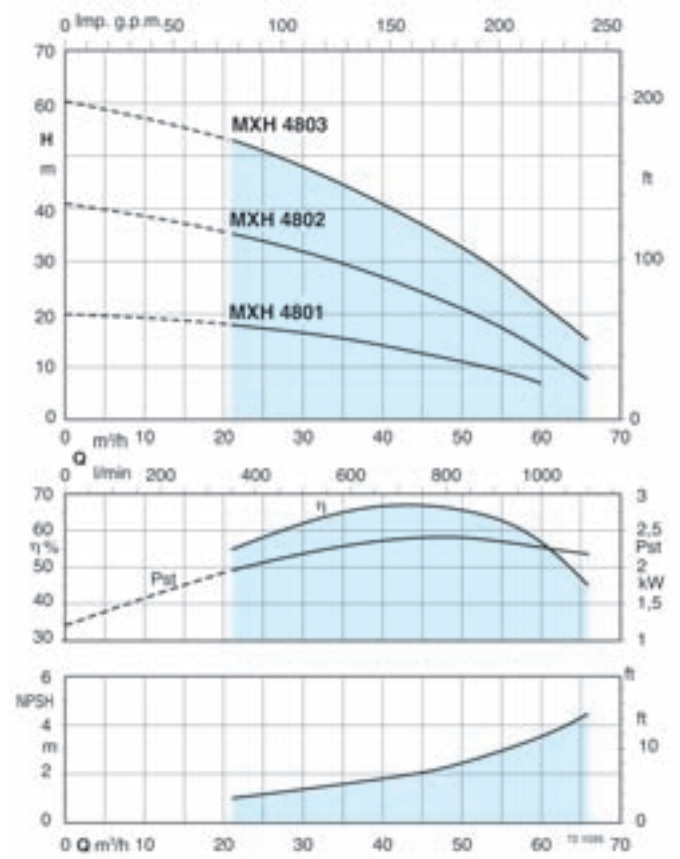
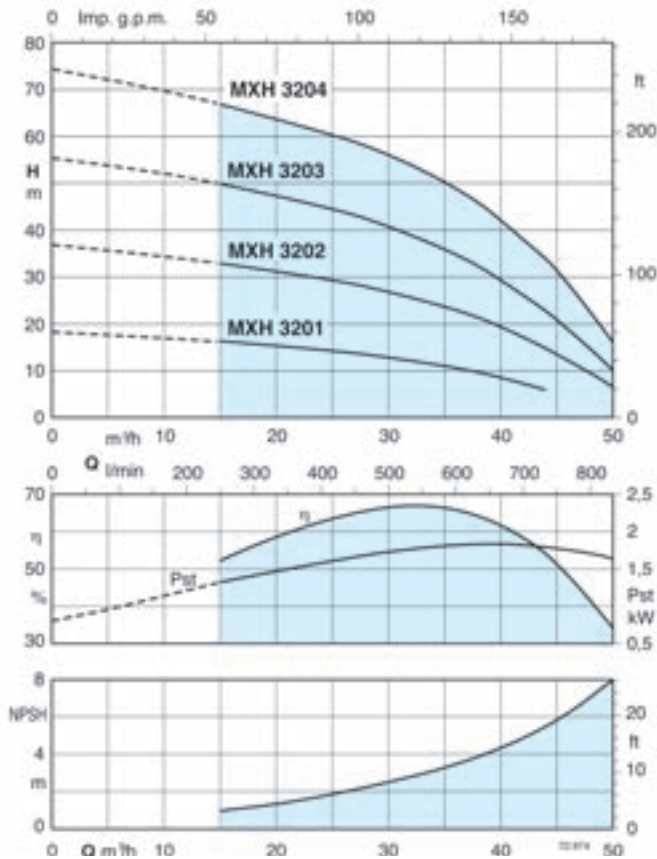

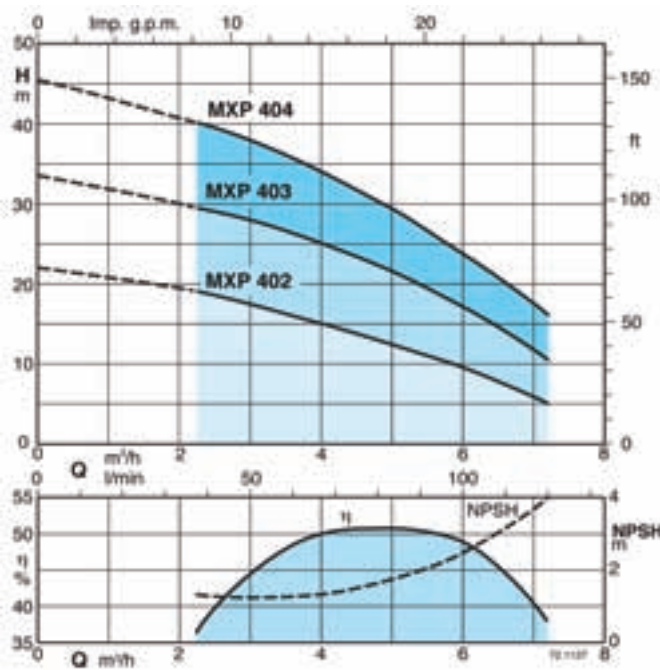
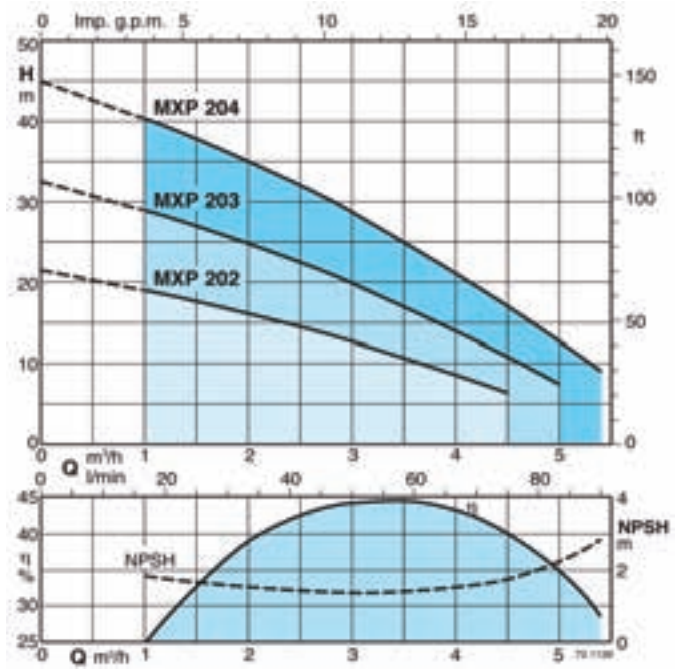
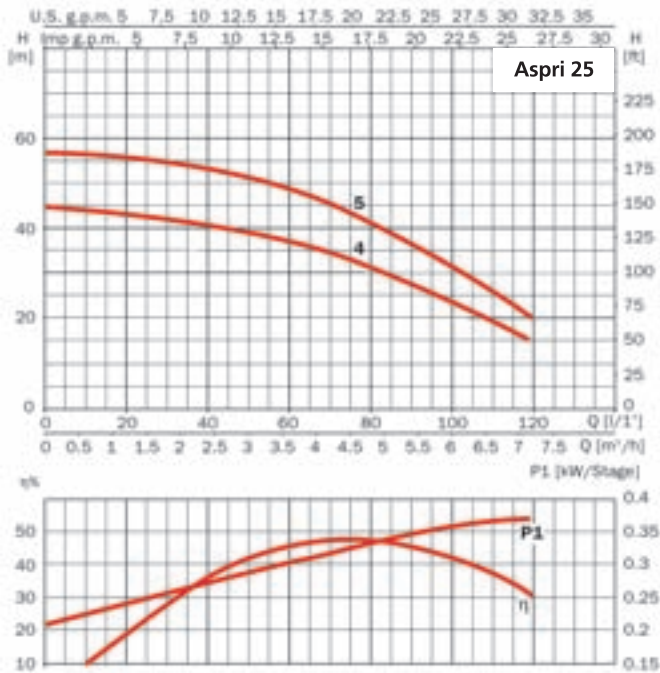

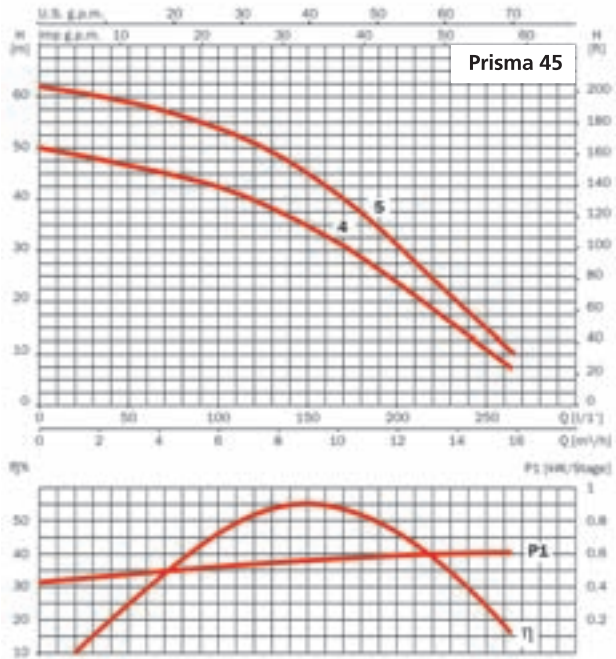
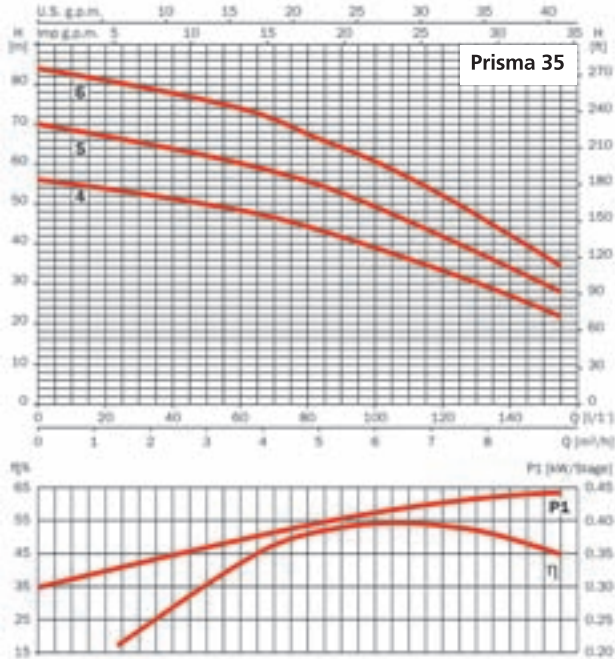

Construction

Pressure boosting sets with automatic operation, consisting of 1, 2 or 3 pump(s) on a common baseplate, with suction and delivery valves and non-return valves, (suction and delivery manifolds in multi-pump units), pressure switches, pressure gauge, float switch, special connector in 1-pump configuration, and control panel as fixed speed with DOL starting.

Suction and delivery manifolds are in AISI304 stainless steel. The unit includes one pressure gauge and adjustable differential pressure switches per pump in the unit.

Designation

DC 3 / MXV 50 - 1605

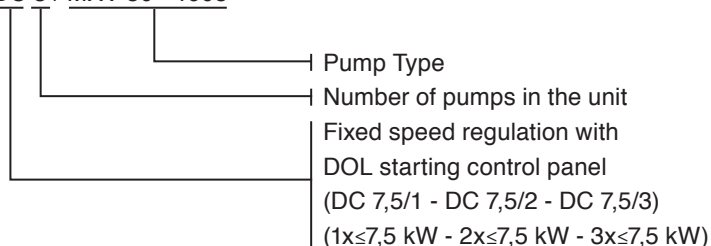

Operation

DC1: According to the pressure decrease in the system, the control panel, with electronic card, manages the pump operation, and it stops the system when there is no water in the tank. Pump starts with a signal from the pressure switch. In particular;

- pump starting according to water demand
- pump stop when there is no water in the suction

DC2/DC3: According to the pressure decrease in the system, the control panel, with electronic card, manages the pump operation, the changeover of pump there is no water in the tank. Pump starting in a cascade sequence, with a signal from the pressure switches.

- pump starting in a cascade sequence according to water demand
- changeover of pump starting sequence
- pumps stop when there is no water in the suction

New electrical control panels for pressurization units, all with electronic card with microprocessor, for managing pump operation. The microprocessor carries out continuous secure check during all the various work phases of the pumps and incorporates all necessary functions, thus reducing electrical and electronic components inside the panel.



Maximum clarity for all signals

The status of the unit can easily be identified on the front of the electronic card with the following signals;

- Power on led
- No water led
- Failure led (1 for each pump)
- Pump running led (1 for each pump)

Maximum simplicity of control

The front of the electronic card features the following signals and controls;

- AUT - STOP - MAN button (1 for each pump)
- RESET push-button

Applications

- Water supply
- Sprinkling
- Irrigation and spraying
- Pumping water from wells and out of low-lying tanks.

Technical Data

- Mains connections 3~400V/50 Hz
- Suction head max. 5 m
- Inlet pressure max. 8 bar
- Fluid temperature +5°C to 110°C
- Operating pressure max. 25 bar
- Differential pressure switch setting range 2-20 bar
- Protection class IP54

Motors

2-pole induction motors, 50 Hz, n=2900 rpm
 Three-phase 230/400 V ± %10
 Insulation class F
 Protection IP54
 Constructed in accordance with IEC 60034
 Other voltages and frequencies on request.

		Q(m ³ /h)						
		0	1	2	3	4		
MXV-B 25 203	H(m)							
MXV-B 25 204		0	42	38	30	22		
MXV-B 25 205		0	52	48	38	26		
MXV-B 25 206		0	62	56	44	32		
MXV-B 25 207		0	76	64	54	44		
MXV-B 25 208		0	84	75	62	45		
MXV-B 25 210		0	105	94	78	56		
MXV 25-212		0	126	112	92	70		
MXV 25-214		0	150	130	108	78		
MXV 25-216		0	170	150	124	90		
MXV 25-218		0	190	170	140	104		
MXV 25-220		0	214	178	155	114		

		Q(m ³ /h)					
		3	4	5	6	7	8
MXV-B 32-403	H(m)						
MXV-B 32-404		40	38	34	28	22	16
MXV-B 32-405		50	46	42	34	26	20
MXV-B 32-406		60	57	50	42	32	24
MXV-B 32-407		70	65	58	50	40	30
MXV-B 32-408/A		80	75	64	54	44	32
MXV-B 32-410/A		100	90	82	70	56	40
MXV 32-412		120	110	98	82	68	48
MXV 32-414		140	130	116	98	78	56
MXV 32-416		162	138	130	110	88	62
MXV 32-418		182	168	145	116	100	70

		Q(m ³ /h)							
		5	6	7	8	9	10	11	12
MXV-B 40-803	H(m)								
MXV-B 40-804		44	42	40	38	36	36	30	28
MXV-B 40-805/A		54	52	50	48	44	42	38	36
MXV-B 40-806/A		64	62	60	58	56	50	44	38
MXV-B 40-807/A		76	74	72	70	66	60	52	48
MXV-B 40-808/A		88	86	84	80	76	68	60	50
MXV-B 40-810/A		110	108	106	100	94	84	82	70
MXV-B 40-811		118	116	112	108	104	94	84	72
MXV-B 40-813		142	138	134	128	120	110	98	84
MXV-B 40-815		164	160	152	150	140	128	114	96
MXV-B 40-817		184	180	174	170	160	144	118	110
MXV-B 40-819		208	202	196	190	178	164	144	122

		Q(m ³ /h)					
		10	12	15	17	20	22
MXV 50-1603	H(m)	50	48	46	40	36	28
MXV 50-1604		62	60	58	52	44	38
MXV 50-1605		80	76	72	64	56	44
MXV 50-1606		94	90	86	78	68	54
MXV 50-1607		110	106	100	90	80	62
MXV 50-1608		118	122	116	106	90	70



		Q(m³/h)							
		15	20	25	30	35	40		
MXV 65-3202	H(m)	35	34	32	30	26	22		
MXV 65-3203		52	50	46	45	38	34		
MXV 65-3204		70	68	64	58	52	45		

		Q(m³/h)							
		25	30	35	40	45	50	55	60
MXV 80-4801	H(m)	18	16	15	14	12	11	10	8
MXV 80-4802		36	34	32	30	28	25	22	18
MXV 80-4803		52	50	48	45	40	36	32	26

		Q(m³/h)					
		30	40	50	60	70	80
MXV100-6501 B	H(m)	22	20	18	16	15	14
MXV100-6501 A		24	24	22	20	18	16
MXV100-6502 C		42	40	38	36	28	20
MXV100-6502 B		50	48	46	40	36	30
MXV100-6502 A		56	54	50	44	42	38

		Q(m³/h)							
		12	15	17	20	22	25	27	30
MV 50-2502	H(m)	32	30	28	25	24	20	15	10
MV 50-2503		46	44	40	35	32	26	22	16
MV 50-2504		62	58	55	50	45	38	30	34
MV 50-2505		75	70	65	60	54	46	38	30
MV 50-2506		93	88	84	76	68	60	50	38

		Q(m³/h)									
		1	2	3	4	5	6	7	8	9	10
MULTI 35 5 N	H(m)	65	64	60	58	62	42	38	30	24	18
MULTI 35 6 N		82	80	76	62	66	60	52	52	36	26
MULTI 35 8 N		118	104	102	96	90	84	72	72	52	40
MULTI 35 10 N		135	130	126	120	112	104	94	80	70	54

		Q(m³/h)								
		2	4	6	8	10	12	14	16	18
MULTI 55 6 N	H(m)	75	72	68	62	58	52	46	40	30
MULTI 55 7 N		88	84	78	72	66	62	54	52	35

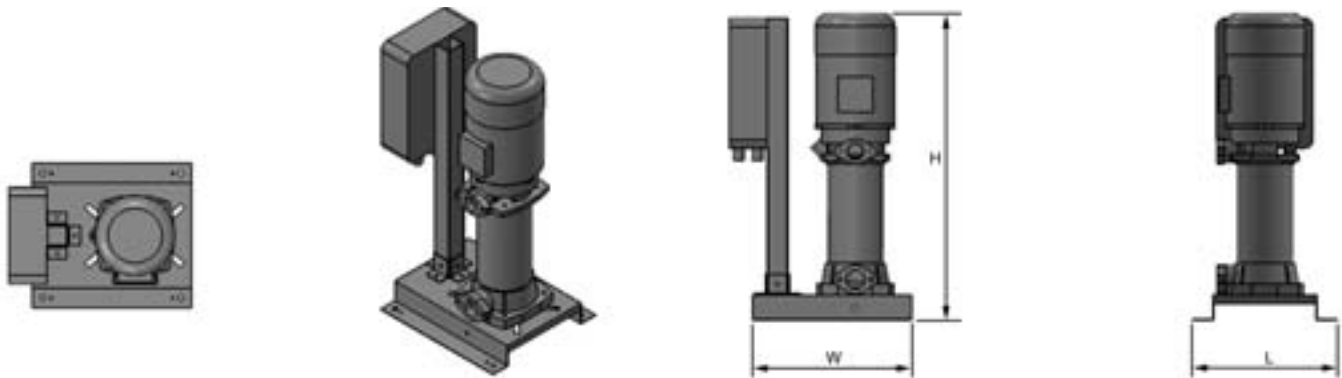

Model	DNs	DNd	W	L	H
DC1-MXV-B 25-204 - 1"-1"	1"	1"	470	400	760
DC1-MXV-B 25-205 - 1"-1"	1"	1"	470	400	760
DC1-MXV-B 25-206 - 1"-1"	1"	1"	470	400	1060
DC1-MXV-B 25-207 - 1"-1"	1"	1"	470	400	1060
DC1-MXV-B 25-208 - 1"-1"	1"	1"	470	400	1060
DC1-MXV-B 25-210 - 1"-1"	1"	1"	470	400	1060
DC1-MXV 25-212 - 1"-1"	1"	1"	470	400	1060
DC1-MXV 25-214 - 1"-1"	1"	1"	470	400	1060
DC1-MXV 25-216 - 1"-1"	1"	1"	470	400	1200
DC1-MXV 25-218 - 1"-1"	1"	1"	470	400	1200
DC1-MXV 25-220 - 1"-1"	1"	1"	470	400	1200
DC1-MXV-B 32-404 - 1¼"-1¼"	1¼"	1¼"	470	420	800
DC1-MXV-B 32-405 - 1¼"-1¼"	1¼"	1¼"	470	420	800
DC1-MXV-B 32-406 - 1¼"-1¼"	1¼"	1¼"	470	420	800
DC1-MXV-B 32-407 - 1¼"-1¼"	1¼"	1¼"	470	420	800
DC1-MXV-B 32-408 - 1¼"-1¼"	1¼"	1¼"	470	420	950
DC1-MXV-B 32-410 - 1¼"-1¼"	1¼"	1¼"	470	420	950
DC1-MXV 32-412 - 1¼"-1¼"	1¼"	1¼"	470	420	1200
DC1-MXV 32-414 - 1¼"-1¼"	1¼"	1¼"	470	420	1200
DC1-MXV 32-416 - 1¼"-1¼"	1¼"	1¼"	470	420	1200
DC1-MXV 32-418 - 1¼"-1¼"	1¼"	1¼"	470	420	1200
DC1-MXV-B 40-804 - 1½"-1½"	1½"	1½"	470	470	950
DC1-MXV-B 40-805 - 1½"-1½"	1½"	1½"	470	470	950
DC1-MXV-B 40-806 - 1½"-1½"	1½"	1½"	470	470	950
DC1-MXV-B 40-807 - 1½"-1½"	1½"	1½"	470	470	950
DC1-MXV-B 40-808 - 1½"-1½"	1½"	1½"	470	470	950
DC1-MXV-B 40-810 - 1½"-1½"	1½"	1½"	470	470	1100
DC1-MXV 40-811 - 1½"-1½"	1½"	1½"	470	470	1100
DC1-MXV 40-813 - 1½"-1½"	1½"	1½"	470	470	1250
DC1-MXV 40-815 - 1½"-1½"	1½"	1½"	470	470	1250
DC1-MXV 40-817 - 1½"-1½"	1½"	1½"	470	470	1250
DC1-MXV 40-819 - 1½"-1½"	1½"	1½"	470	470	1250

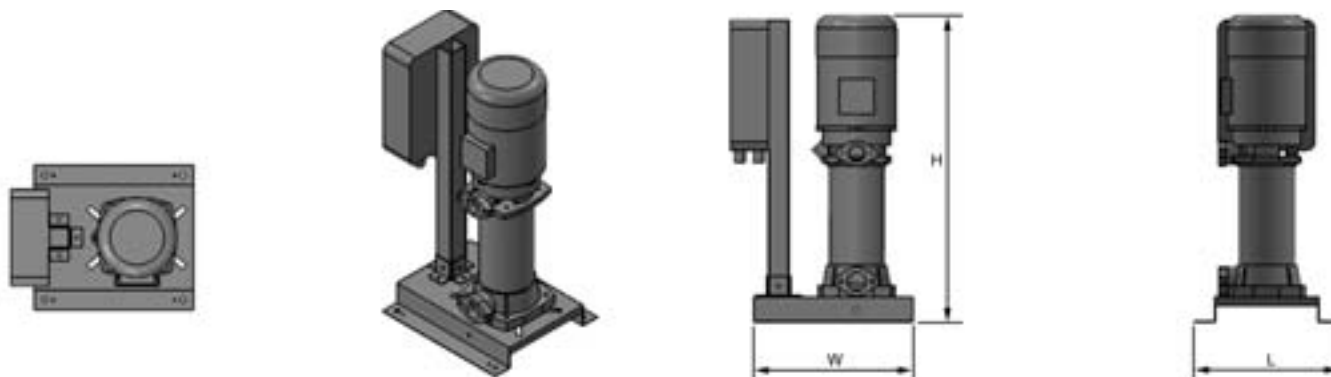

Model	DNs	DNd	W	L	H
DC1-MXV50-1603	2"	2"	550	550	1100
DC1-MXV50-1604	2"	2"	550	550	1100
DC1-MXV50-1605	2"	2"	550	550	1100
DC1-MXV50-1606	2"	2"	550	550	1100
DC1-MXV50-1607	2"	2"	550	550	1100
DC1-MXV50-1608	2"	2"	550	550	1100
SDC1-MXV50-1609	2"	2"	550	550	1550
SDC1-MXV50-1610	2"	2"	550	550	1550
SDC1-MXV50-1611	2"	2"	550	550	1550
SDC1-MXV50-1612	2"	2"	550	550	1550
SDC1-MXV50-1614	2"	2"	550	550	1550
SDC1-MXV50-1616	2"	2"	550	550	1550
DC1-MXV65-3202	DN65	DN65	500	700	1050
DC1-MXV65-3203	DN65	DN65	500	700	1050
DC1-MXV65-3204	DN65	DN65	500	700	1050
SDC1-MXV65-3205	DN65	DN65	500	700	1650
SDC1-MXV65-3206	DN65	DN65	500	700	1650
SDC1-MXV65-3207	DN65	DN65	500	700	1650
SDC1-MXV65-3208	DN65	DN65	500	700	1650
SDC1-MXV65-3209	DN65	DN65	500	700	1650
SDC1-MXV65-3210	DN65	DN65	500	700	1650
SDC1-MXV65-3212	DN65	DN65	500	700	1650
DC1-MXV80-4801	DN80	DN80	500	700	1050
DC1-MXV80-4802	DN80	DN80	500	700	1050
DC1-MXV80-4803	DN80	DN80	500	700	1050
SDC1-MXV80-4804	DN80	DN80	500	700	1650
SDC1-MXV80-4805	DN80	DN80	500	700	1650
SDC1-MXV80-4806	DN80	DN80	500	700	1650
SDC1-MXV80-4807	DN80	DN80	500	700	1650
SDC1-MXV80-4808	DN80	DN80	500	700	1650

DC1 / DC2 / DC3

Automatic Water Boosters Fixed Speed Pump Units

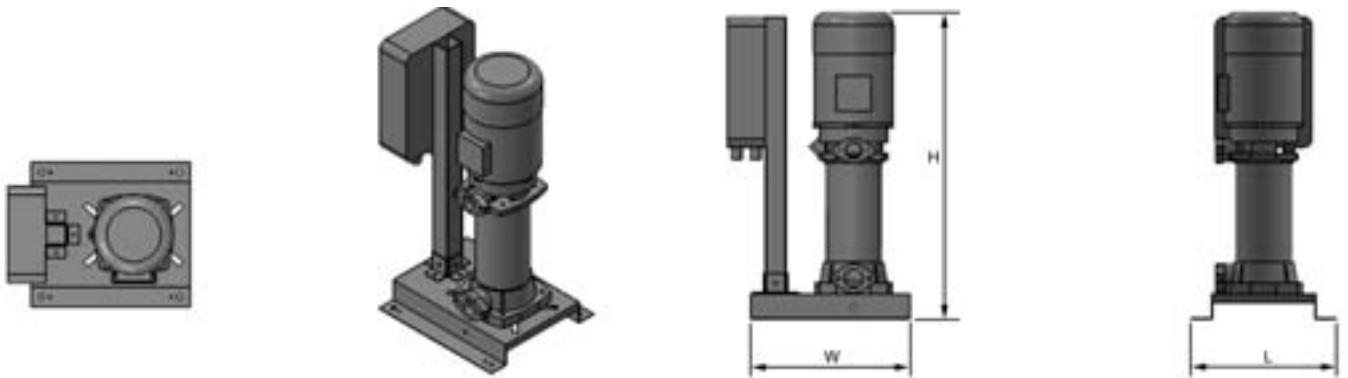

Model	DNs	DNd	W	L	H
DC1-MV 50-2502-DN50/DN50	2"	2"	550	550	1200
DC1-MV 50-2503-DN50/DN50	2"	2"	550	550	1200
DC1-MV 50-2504-DN50/DN50	2"	2"	550	550	1200
DC1-MV 50-2505-DN50/DN50	2"	2"	550	550	1200
DC1-MV 50-2506-DN50/DN50	2"	2"	550	550	1200
DC1-MV 50-2507-DN50/DN50	2"	2"	550	550	1650
DC1-MV 50-2508-DN50/DN50	2"	2"	550	550	1650
DC1-MV 50-2509-DN50/DN50	2"	2"	550	550	1650
DC1-MV 50-2510-DN50/DN50	2"	2"	550	550	1650
DC1-MULTI 35/5 - 1½"-1¼"	1½"	1¼"	470	400	760
DC1-MULTI 35/6 - 1½"-1¼"	1½"	1¼"	470	400	760
DC1-MULTI 35/8 - 1½"-1¼"	1½"	1¼"	470	400	760
DC1-MULTI 35/10 - 1½"-1¼"	1½"	1¼"	470	400	950
DC1-MULTI 55/6 - 1½"-1¼"	1½"	1¼"	470	400	950
DC1-MULTI 55/7 - 1½"-1¼"	1½"	1¼"	470	400	950

DC1 / DC2 / DC3

Automatic Water Boosters Fixed Speed Pump Units

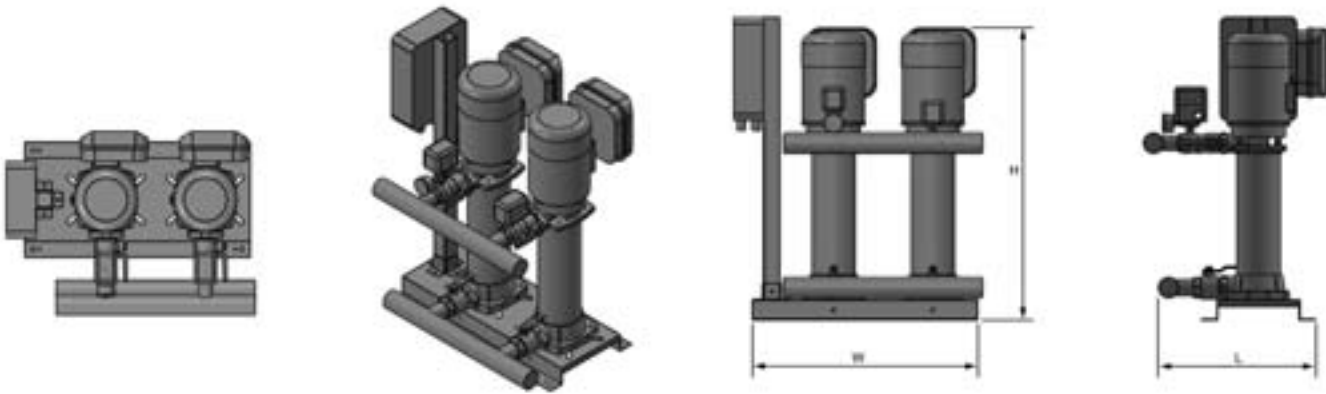

Model	DNs	DNd	W	L	H
DC2-MXV-B 25-204 - 1½"-1½"	1½"	1½"	780	700	760
DC2-MXV-B 25-205 - 1½"-1½"	1½"	1½"	780	700	760
DC2-MXV-B 25-206 - 1½"-1½"	1½"	1½"	780	700	1060
DC2-MXV-B 25-207 - 1½"-1½"	1½"	1½"	780	700	1060
DC2-MXV-B 25-208 - 1½"-1½"	1½"	1½"	780	700	1060
DC2-MXV-B 25-210 - 1½"-1½"	1½"	1½"	780	700	1060
DC2-MXV 25-212 - 1½"-1½"	1½"	1½"	780	700	1060
DC2-MXV 25-214 - 1½"-1½"	1½"	1½"	780	700	1060
DC2-MXV 25-216 - 1½"-1½"	1½"	1½"	780	700	1200
DC2-MXV 25-218 - 1½"-1½"	1½"	1½"	780	700	1200
DC2-MXV 25-220 - 1½"-1½"	1½"	1½"	780	700	1200
DC2-MXV-B 32-404 - 2"-2"	2"	2"	780	700	800
DC2-MXV-B 32-405 - 2"-2"	2"	2"	780	700	800
DC2-MXV-B 32-406 - 2"-2"	2"	2"	780	700	800
DC2-MXV-B 32-407 - 2"-2"	2"	2"	780	700	800
DC2-MXV-B 32-408 - 2"-2"	2"	2"	780	700	950
DC2-MXV-B 32-410 - 2"-2"	2"	2"	780	700	950
DC2-MXV 32-412 - 2"-2"	2"	2"	780	700	1200
DC2-MXV 32-414 - 2"-2"	2"	2"	780	700	1200
DC2-MXV 32-416 - 2"-2"	2"	2"	780	700	1200
DC2-MXV 32-418 - 2"-2"	2"	2"	780	700	1200
DC2-MXV-B 40-804 - 2"-2"	2"	2"	780	700	950
DC2-MXV-B 40-805 - 2"-2"	2"	2"	780	700	950
DC2-MXV-B 40-806 - 2"-2"	2"	2"	780	700	950
DC2-MXV-B 40-807 - 2"-2"	2"	2"	780	700	950
DC2-MXV-B 40-808 - 2"-2"	2"	2"	780	700	950
DC2-MXV-B 40-810 - 2"-2"	2"	2"	780	700	1100
DC2-MXV 40-811 - 2"-2"	2"	2"	780	700	1100
DC2-MXV 40-813 - 2"-2"	2"	2"	780	700	1250
DC2-MXV 40-815 - 2"-2"	2"	2"	780	700	1250
DC2-MXV 40-817 - 2"-2"	2"	2"	780	700	1250
DC2-MXV 40-819 - 2"-2"	2"	2"	780	700	1250

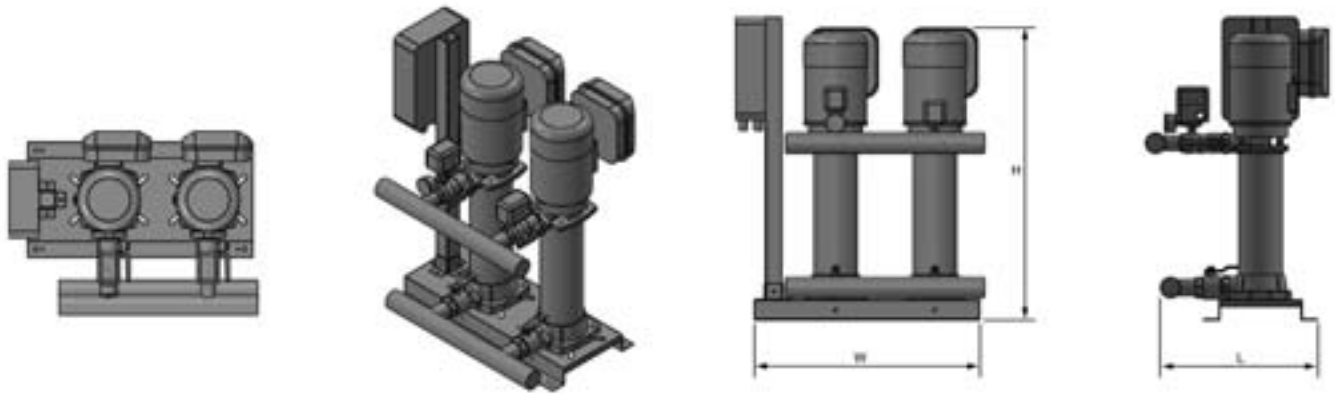

Model	DNs	DNd	W	L	H
DC2-MXV50-1603	3"	2½"	800	950	1100
DC2-MXV50-1604	3"	2½"	800	950	1100
DC2-MXV50-1605	3"	2½"	800	950	1100
DC2-MXV50-1606	3"	2½"	800	950	1100
DC2-MXV50-1607	3"	2½"	800	950	1100
DC2-MXV50-1608	3"	2½"	800	950	1100
SDC2-MXV50-1609	3"	2½"	800	950	1550
SDC2-MXV50-1610	3"	2½"	800	950	1550
SDC2-MXV50-1611	3"	2½"	800	950	1550
SDC2-MXV50-1612	3"	2½"	800	950	1550
SDC2-MXV50-1614	3"	2½"	800	950	1550
SDC2-MXV50-1616	3"	2½"	800	950	1550
DC2-MXV65-3202	DN100	DN100	1300	1230	1050
DC2-MXV65-3203	DN100	DN100	1300	1230	1050
DC2-MXV65-3204	DN100	DN100	1300	1230	1050
SDC2-MXV65-3205	DN100	DN100	1300	1230	1650
SDC2-MXV65-3206	DN100	DN100	1300	1230	1650
SDC2-MXV65-3207	DN100	DN100	1300	1230	1650
SDC2-MXV65-3208	DN100	DN100	1300	1230	1650
SDC2-MXV65-3209	DN100	DN100	1300	1230	1650
SDC2-MXV65-3210	DN100	DN100	1300	1230	1650
SDC2-MXV65-3212	DN100	DN100	1300	1230	1650
DC2-MXV80-4801	DN125	DN125	1300	1300	1050
DC2-MXV80-4802	DN125	DN125	1300	1300	1050
DC2-MXV80-4803	DN125	DN125	1300	1300	1050
SDC2-MXV80-4804	DN125	DN125	1300	1300	1650
SDC2-MXV80-4805	DN125	DN125	1300	1300	1650
SDC2-MXV80-4806	DN125	DN125	1300	1300	1650
SDC2-MXV80-4807	DN125	DN125	1300	1300	1650
SDC2-MXV80-4808	DN125	DN125	1300	1300	1650

DC1 / DC2 / DC3

Automatic Water Boosters Fixed Speed Pump Units

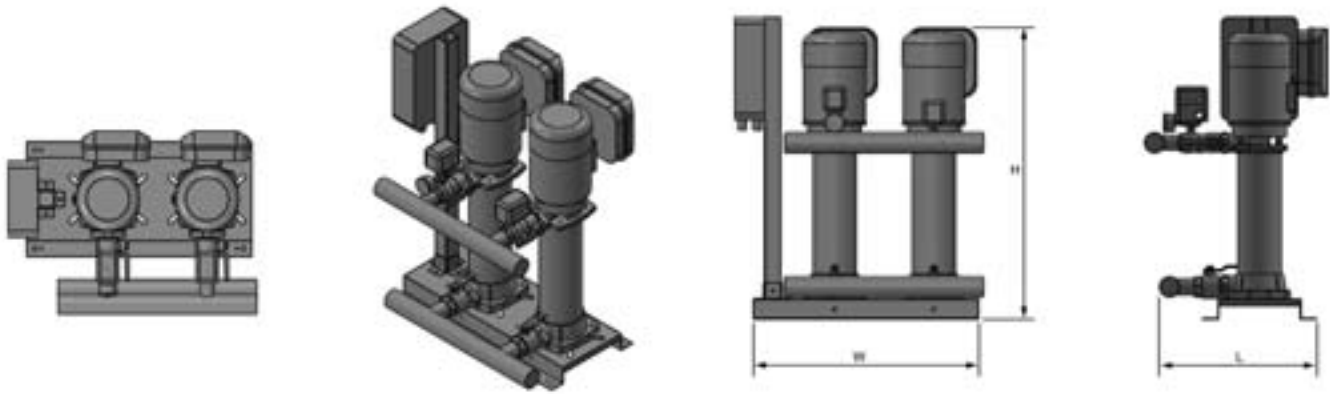

Model	DNs	DNd	W	L	H
DC2-MV 50-2502-3"-2½"	3"	2½"	800	950	1200
DC2-MV 50-2503-3"-2½"	3"	2½"	800	950	1200
DC2-MV 50-2504-3"-2½"	3"	2½"	800	950	1200
DC2-MV 50-2505-3"-2½"	3"	2½"	800	950	1200
DC2-MV 50-2506-3"-2½"	3"	2½"	800	950	1200
DC2-MV 50-2507-3"-2½"	3"	2½"	800	950	1650
DC2-MV 50-2508-3"-2½"	3"	2½"	800	950	1650
DC2-MV 50-2509-3"-2½"	3"	2½"	800	950	1650
DC2-MV 50-2510-3"-2½"	3"	2½"	800	950	1650
DC2-MULTI 35/5 - 2"-2"	2"	2"	780	560	760
DC2-MULTI 35/6 - 2"-2"	2"	2"	780	560	760
DC2-MULTI 35/8 - 2"-2"	2"	2"	780	560	760
DC2-MULTI 35/10 - 2"-2"	2"	2"	780	560	950
DC2-MULTI 55/6 - 2"-2"	2"	2"	780	560	950
DC2-MULTI 55/7 - 2"-2"	2"	2"	780	560	950

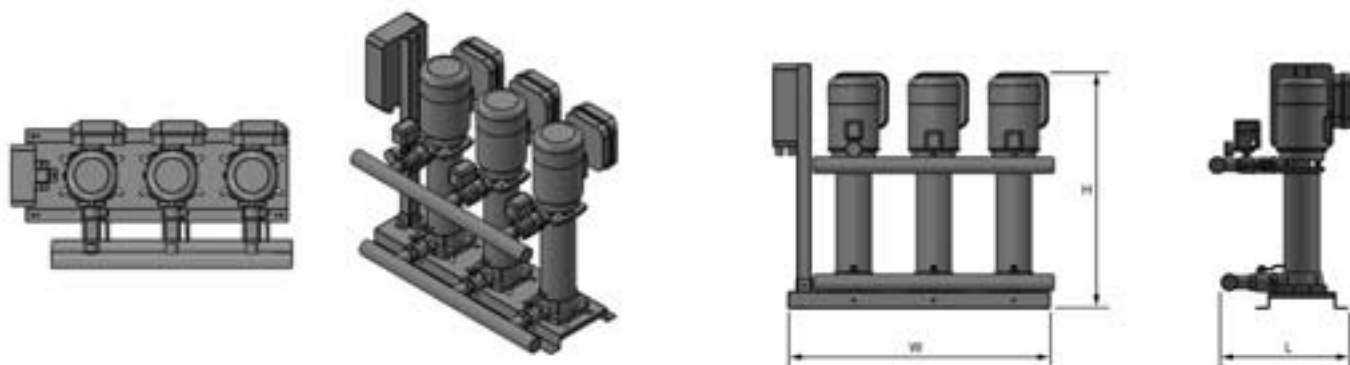

Model	DNs	DNd	W	L	H
DC3-MXV-B 25-204 - 2"-2"	2"	2"	1080	700	1060
DC3-MXV-B 25-205 - 2"-2"	2"	2"	1080	700	1060
DC3-MXV-B 25-206 - 2"-2"	2"	2"	1080	700	1060
DC3-MXV-B 25-207 - 2"-2"	2"	2"	1080	700	1060
DC3-MXV-B 25-208 - 2"-2"	2"	2"	1080	700	1060
DC3-MXV-B 25-210 - 2"-2"	2"	2"	1080	700	1060
DC3-MXV 25-212 - 2"-2"	2"	2"	1080	700	1060
DC3-MXV 25-214 - 2"-2"	2"	2"	1080	700	1060
DC3-MXV 25-216 - 2"-2"	2"	2"	1080	700	1200
DC3-MXV 25-218 - 2"-2"	2"	2"	1080	700	1200
DC3-MXV 25-220 - 2"-2"	2"	2"	1080	700	1200
DC3-MXV-B 32-404 - 2"-2"	2"	2"	1080	700	950
DC3-MXV-B 32-405 - 2"-2"	2"	2"	1080	700	950
DC3-MXV-B 32-406 - 2"-2"	2"	2"	1080	700	950
DC3-MXV-B 32-407 - 2"-2"	2"	2"	1080	700	950
DC3-MXV-B 32-408 - 2"-2"	2"	2"	1080	700	950
DC3-MXV-B 32-410 - 2"-2"	2"	2"	1080	700	950
DC3-MXV 32-412 - 2"-2"	2"	2"	1080	700	1200
DC3-MXV 32-414 - 2"-2"	2"	2"	1080	700	1200
DC3-MXV 32-416 - 2"-2"	2"	2"	1080	700	1200
DC3-MXV 32-418 - 2"-2"	2"	2"	1080	700	1200
DC3-MXV-B 40-804 - 2½"-2½"	2½"	2½"	1080	750	950
DC3-MXV-B 40-805 - 2½"-2½"	2½"	2½"	1080	750	950
DC3-MXV-B 40-806 - 2½"-2½"	2½"	2½"	1080	750	950
DC3-MXV-B 40-807 - 2½"-2½"	2½"	2½"	1080	750	950
DC3-MXV-B 40-808 - 2½"-2½"	2½"	2½"	1080	750	950
DC3-MXV-B 40-810 - 2½"-2½"	2½"	2½"	1080	750	1100
DC3-MXV 40-811 - 2½"-2½"	2½"	2½"	1080	750	1100
DC3-MXV 40-813 - 2½"-2½"	2½"	2½"	1080	750	1250
DC3-MXV 40-815 - 2½"-2½"	2½"	2½"	1080	750	1250
DC3-MXV 40-817 - 2½"-2½"	2½"	2½"	1080	750	1250
DC3-MXV 40-819 - 2½"-2½"	2½"	2½"	1080	750	1250

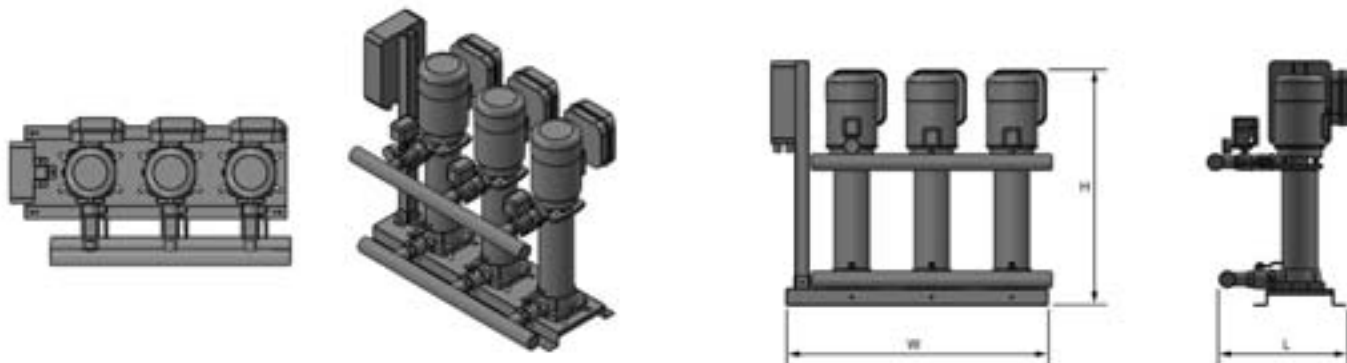

Model	DNs	DNd	W	L	H
DC3-MXV50-1603	DN100	3"	1200	1000	1100
DC3-MXV50-1604	DN100	3"	1200	1000	1100
DC3-MXV50-1605	DN100	3"	1200	1000	1100
DC3-MXV50-1606	DN100	3"	1200	1000	1100
DC3-MXV50-1607	DN100	3"	1200	1000	1100
DC3-MXV50-1608	DN100	3"	1200	1000	1100
SDC3-MXV50-1609	DN100	3"	1200	1000	1550
SDC3-MXV50-1610	DN100	3"	1200	1000	1550
SDC3-MXV50-1611	DN100	3"	1200	1000	1550
SDC3-MXV50-1612	DN100	3"	1200	1000	1550
SDC3-MXV50-1614	DN100	3"	1200	1000	1550
SDC3-MXV50-1616	DN100	3"	1200	1000	1550
DC3-MXV65-3202	DN125	DN125	1800	1300	1050
DC3-MXV65-3203	DN125	DN125	1800	1300	1050
DC3-MXV65-3204	DN125	DN125	1800	1300	1050
SDC3-MXV65-3205	DN125	DN125	1800	1300	1650
SDC3-MXV65-3206	DN125	DN125	1800	1300	1650
SDC3-MXV65-3207	DN125	DN125	1800	1300	1650
SDC3-MXV65-3208	DN125	DN125	1800	1300	1650
SDC3-MXV65-3209	DN125	DN125	1800	1300	1650
SDC3-MXV65-3210	DN125	DN125	1800	1300	1650
SDC3-MXV65-3212	DN125	DN125	1800	1300	1650
DC3-MXV80-4801	DN150	DN150	1800	1400	1050
DC3-MXV80-4802	DN150	DN150	1800	1400	1050
DC3-MXV80-4803	DN150	DN150	1800	1400	1050
SDC3-MXV80-4804	DN150	DN150	1800	1400	1650
SDC3-MXV80-4805	DN150	DN150	1800	1400	1650
SDC3-MXV80-4806	DN150	DN150	1800	1400	1650
SDC3-MXV80-4807	DN150	DN150	1800	1400	1650
SDC3-MXV80-4808	DN150	DN150	1800	1400	1650

DC1 / DC2 / DC3 Automatic Water Boosters Fixed Speed Pump Units

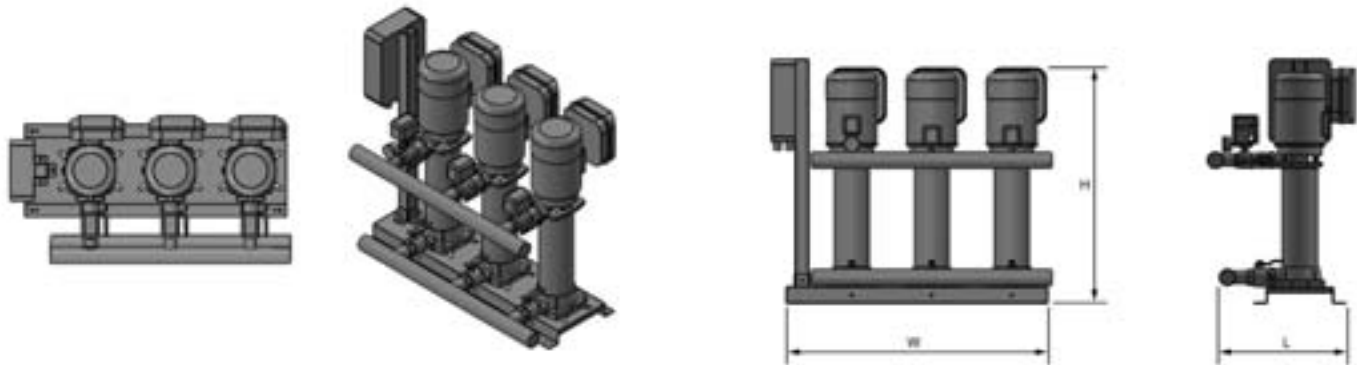

Model	DNs	DNd	W	L	H
DC3-MV 50-2502-DN100/3"	DN100	3"	1200	1000	1200
DC3-MV 50-2503-DN100/3"	DN100	3"	1200	1000	1200
DC3-MV 50-2504-DN100/3"	DN100	3"	1200	1000	1200
DC3-MV 50-2505-DN100/3"	DN100	3"	1200	1000	1200
DC3-MV 50-2506-DN100/3"	DN100	3"	1200	1000	1200
DC3-MV 50-2507-DN100/3"	DN100	3"	1200	1000	1650
DC3-MV 50-2508-DN100/3"	DN100	3"	1200	1000	1650
DC3-MV 50-2509-DN100/3"	DN100	3"	1200	1000	1650
DC3-MV 50-2510-DN100/3"	DN100	3"	1200	1000	1650
DC3-MULTI 35/5 - 2½"-2"	2½"	2"	1080	560	950
DC3-MULTI 35/6 - 2½"-2"	2½"	2"	1080	560	950
DC3-MULTI 35/8 - 2½"-2"	2½"	2"	1080	560	950
DC3-MULTI 35/10 - 2½"-2"	2½"	2"	1080	560	950
DC3-MULTI 55/6 - 2½"-2"	2½"	2"	1080	560	950
DC3-MULTI 55/7 - 2½"-2"	2½"	2"	1080	560	950

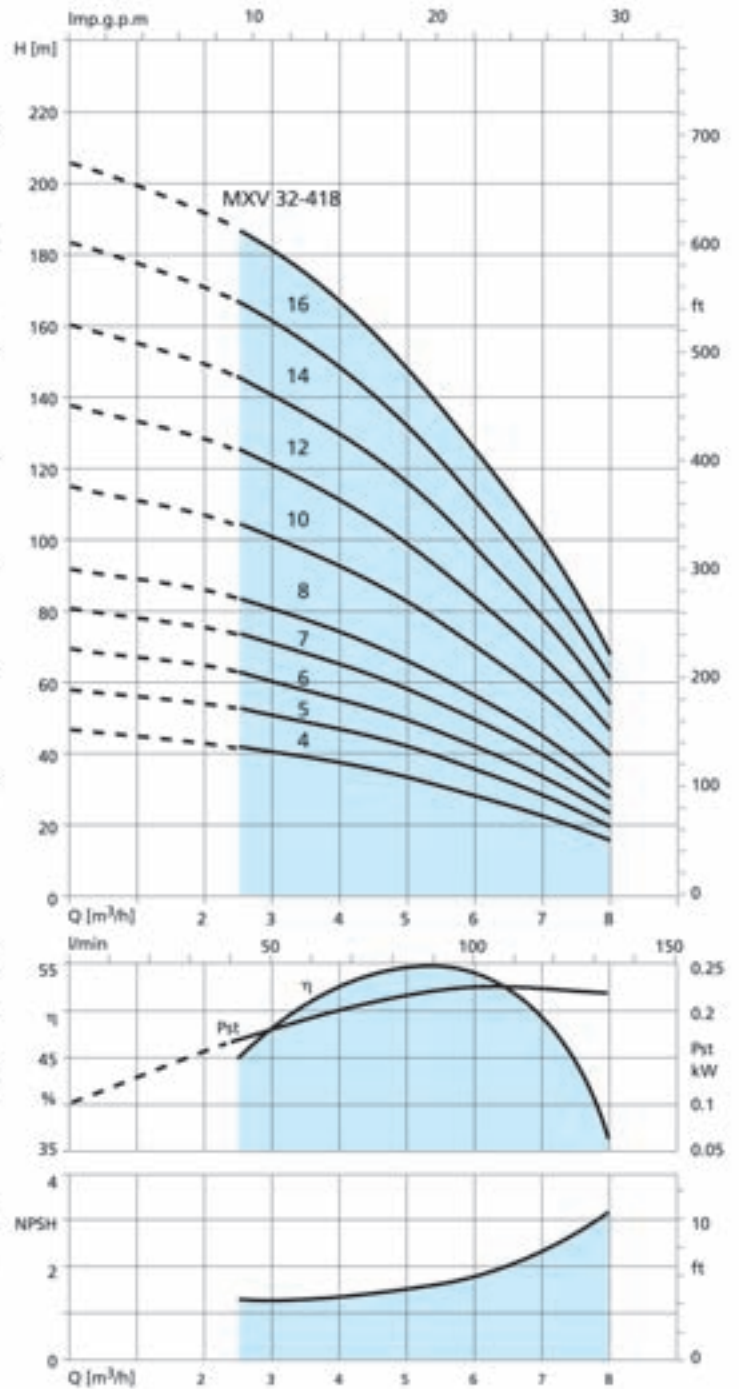
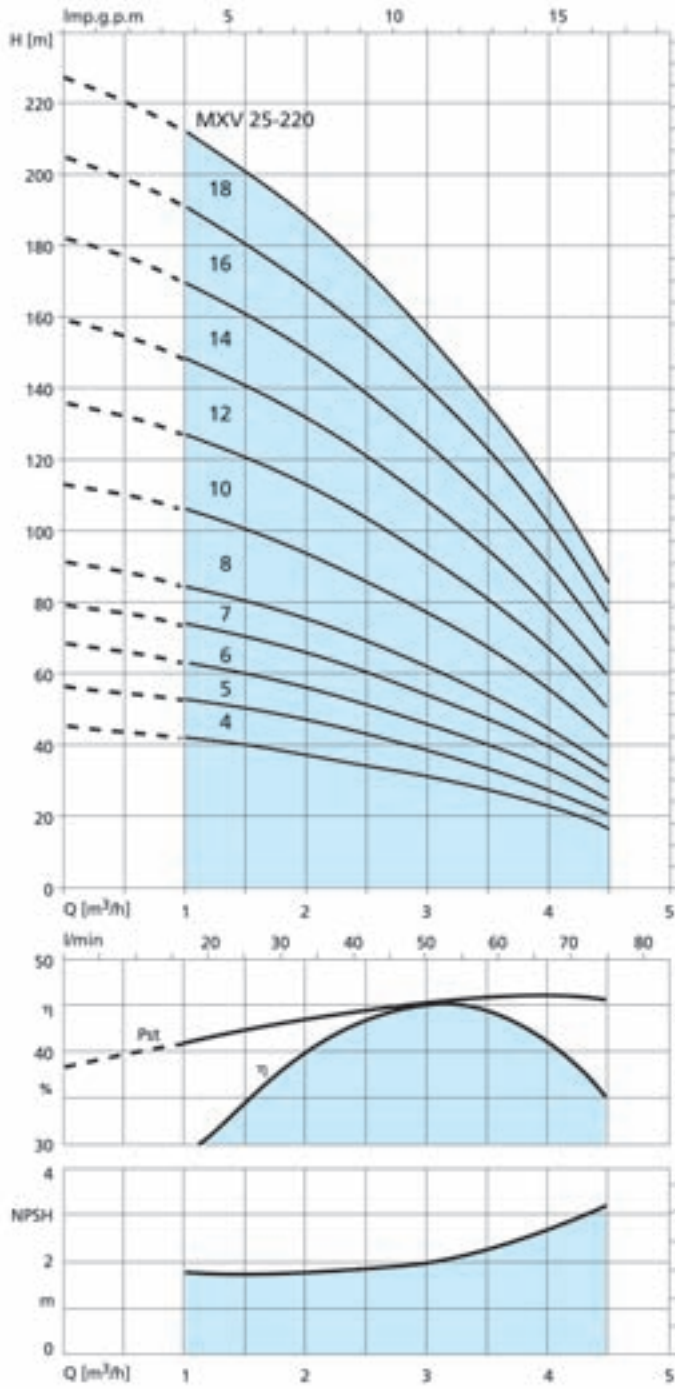

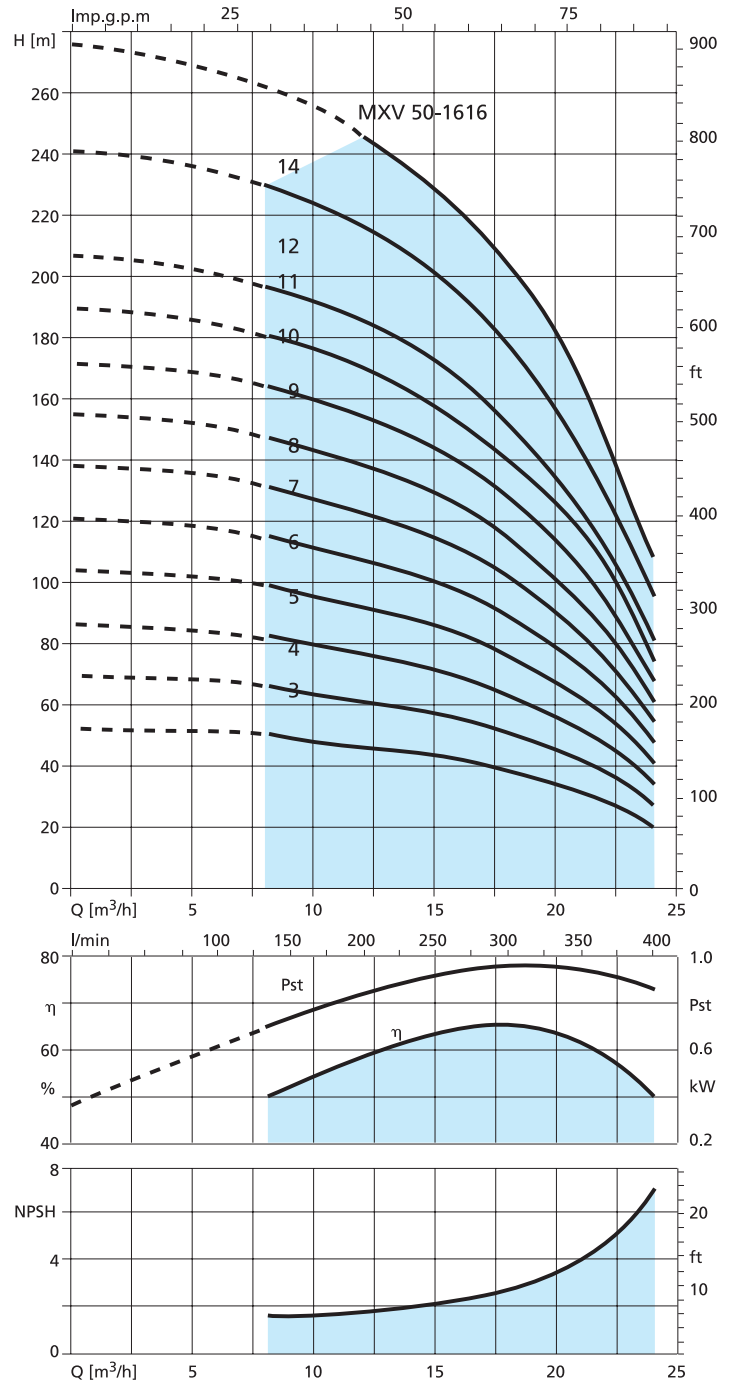
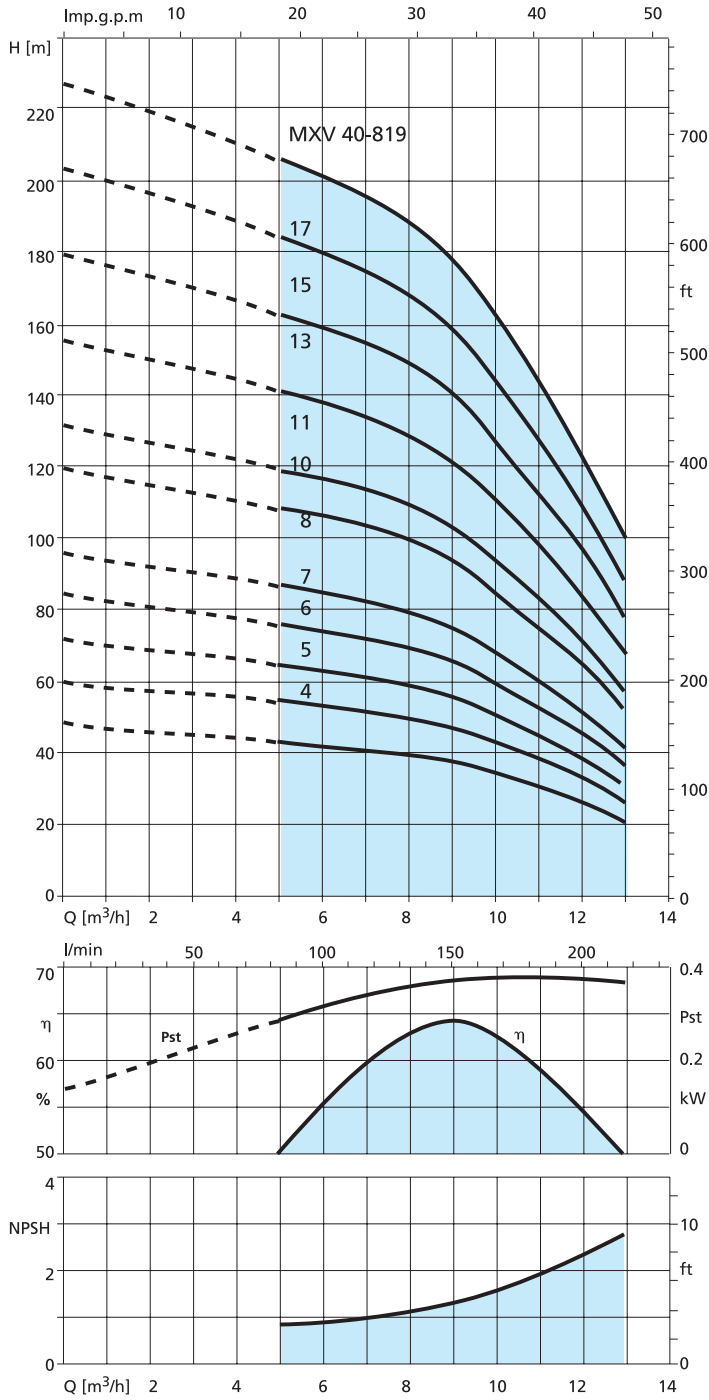

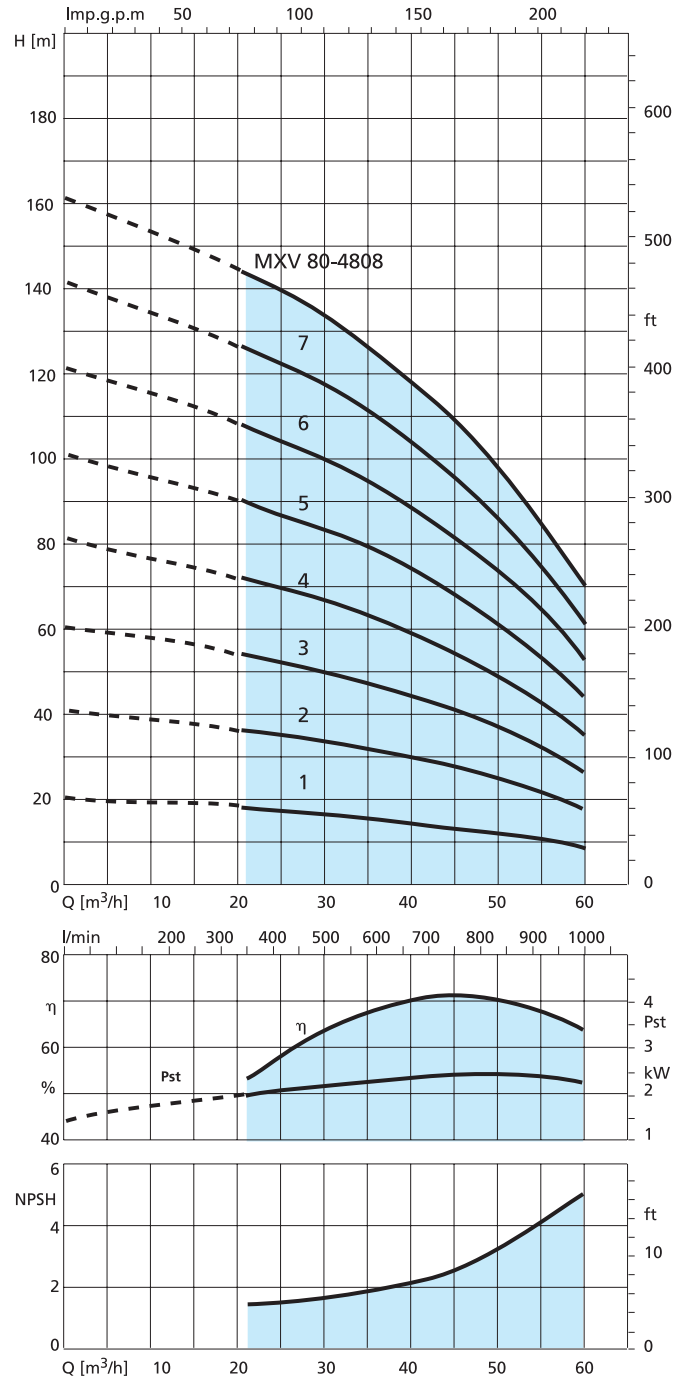
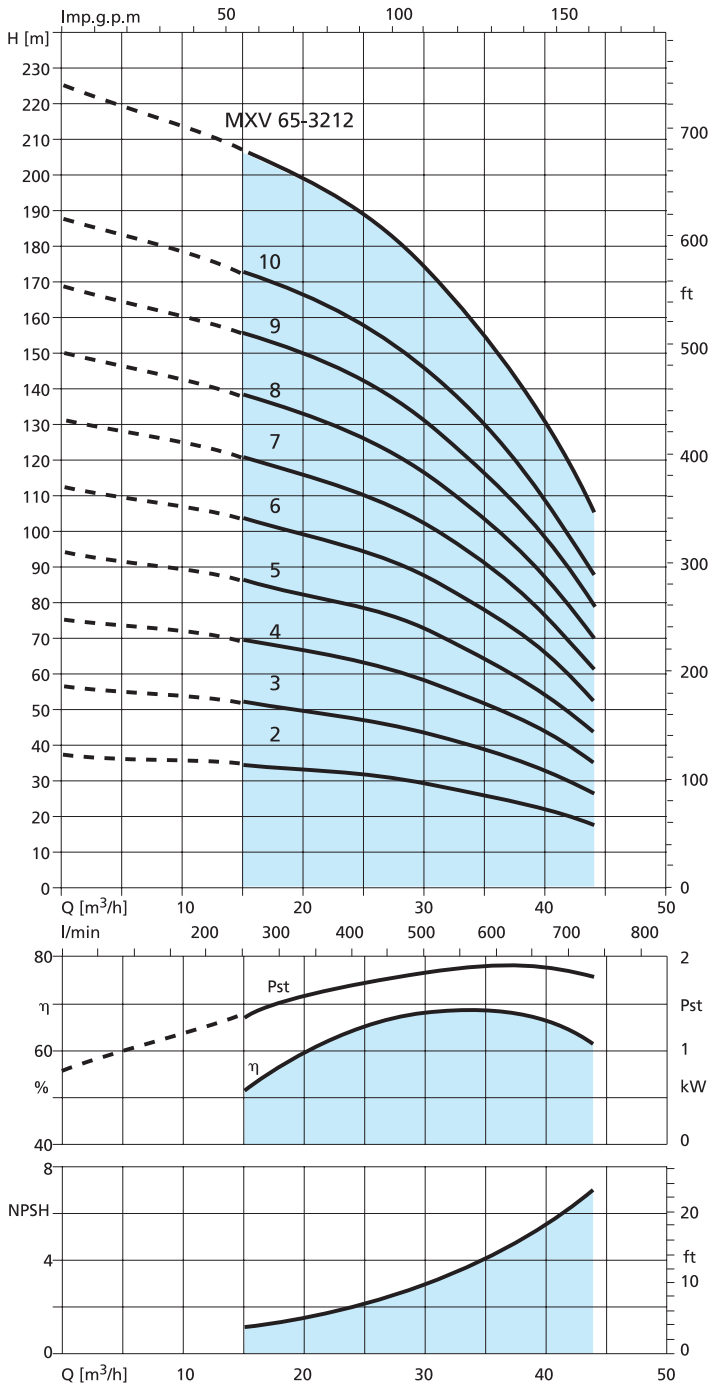

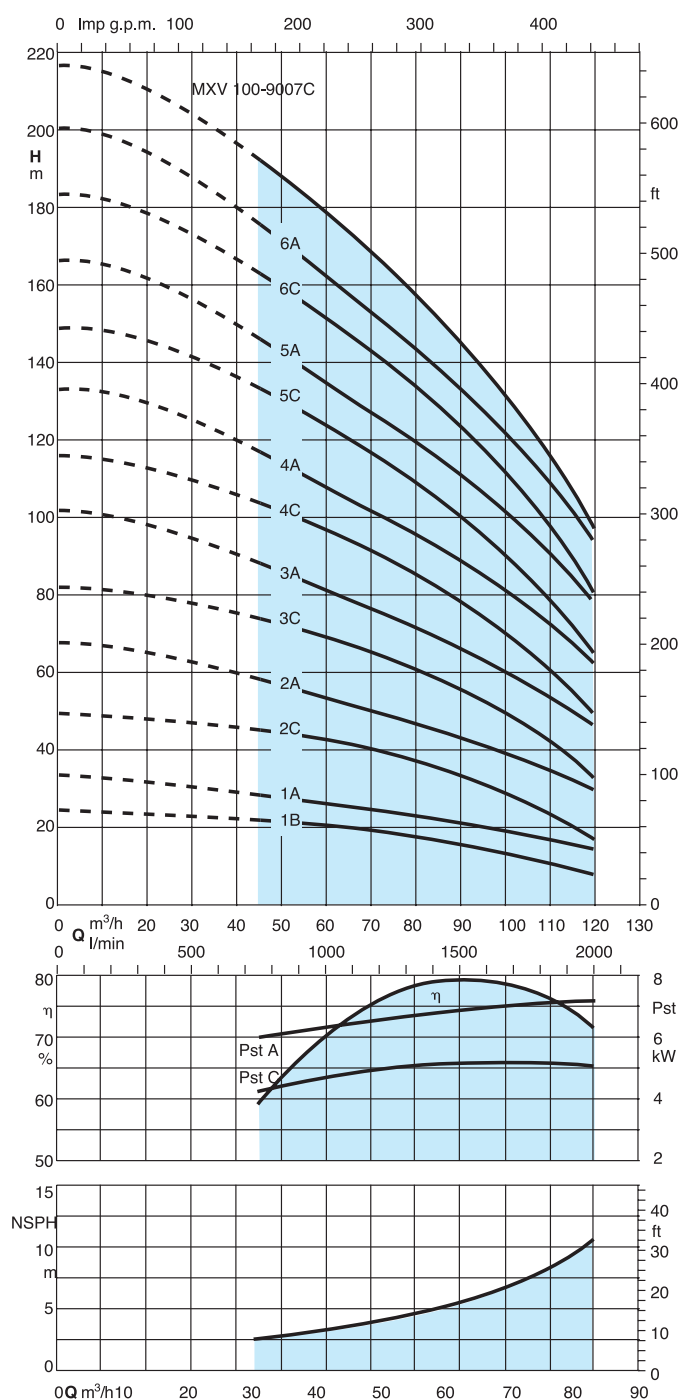
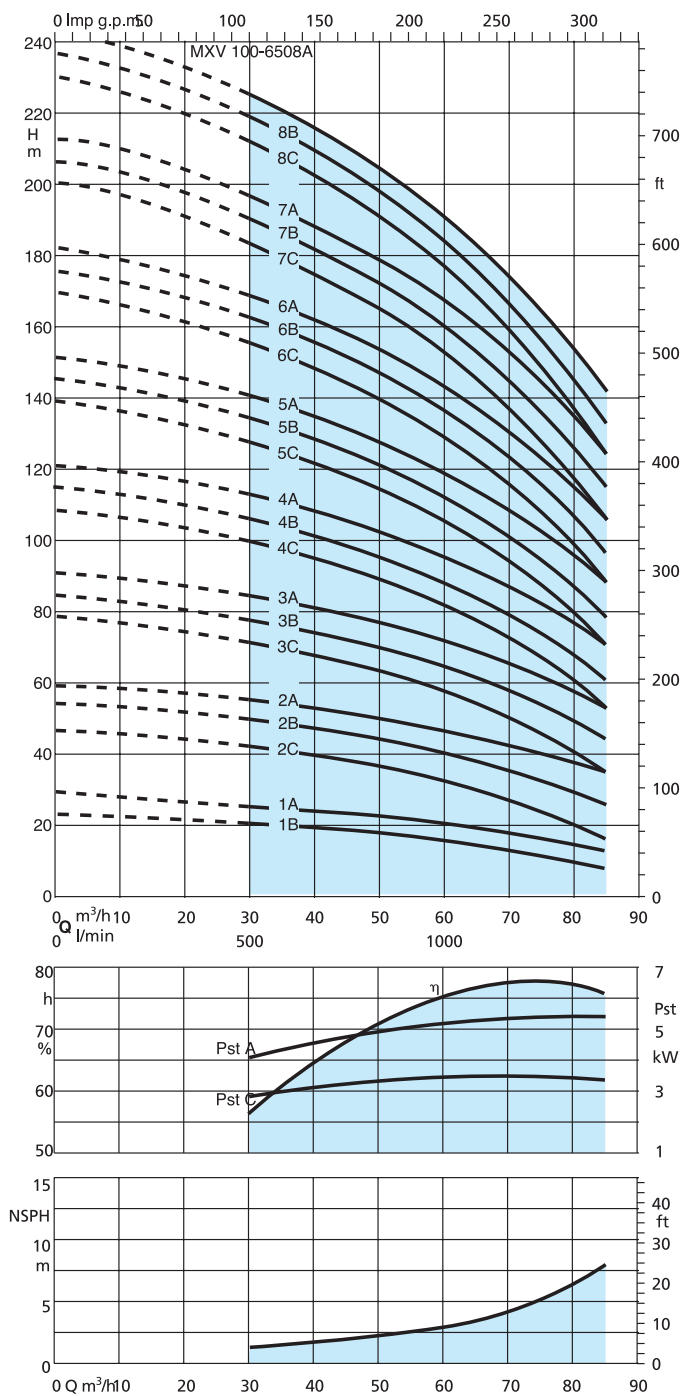

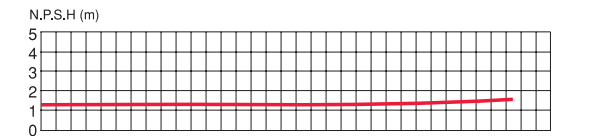
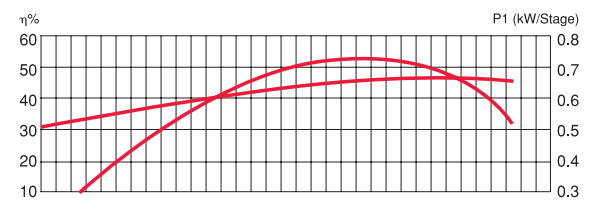
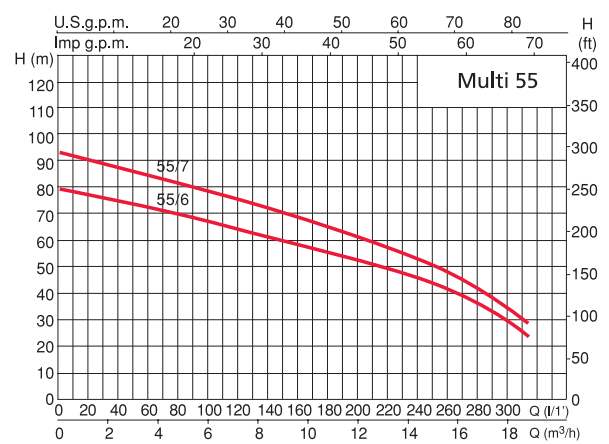
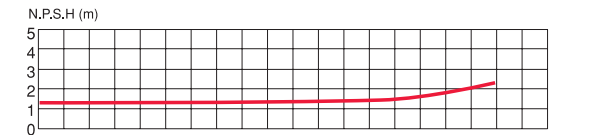
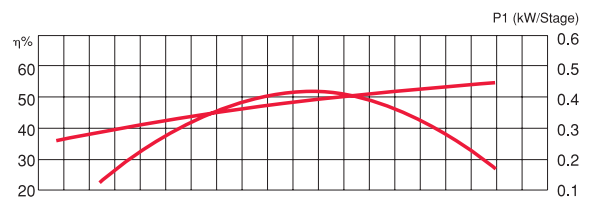
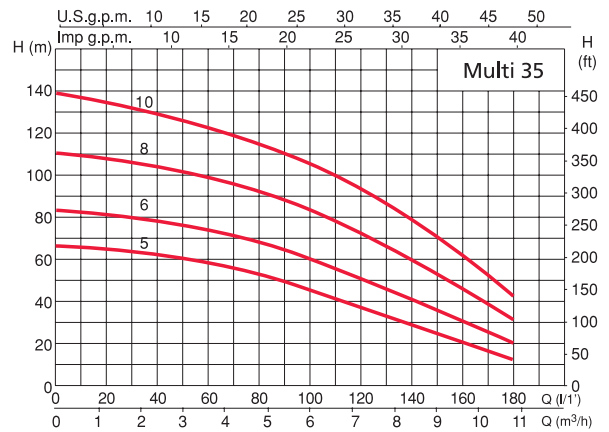
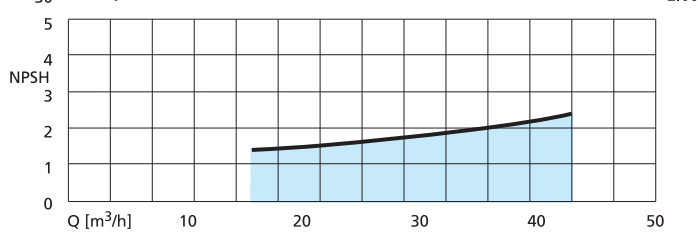
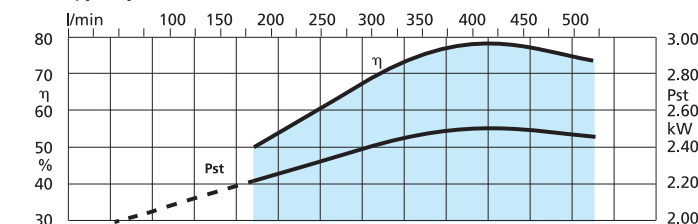
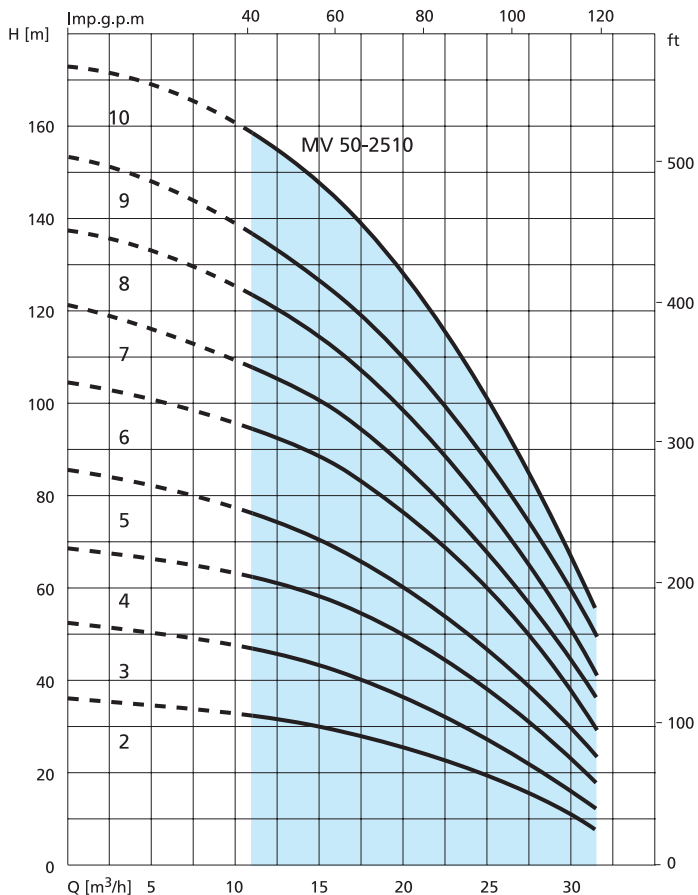



ESPA
Efficient
Engineering

FAULT

RUN

LINE

OK

Speedrive

More control, performance and efficiency





ESPA
*Efficient
Engineering*

Speedrive

ESPA Efficient Engineering

Performance. Energy efficiency. Durability. Reliability.

ESPA now provides a competitive, versatile and cost-effective response to the increasing demands of the market.

ESPA Speedrive (ESD) is an innovative variable-frequency drive system which offers high hydraulic performance for pumping and pressurisation operations; constant pressure without flow fluctuations; savings in energy consumption; smooth, quiet operation; increased service life for the pumps; reduced life cycle costs (**LCC**).

In other words: convenience, sustainability, performance and cost-effectiveness, thanks to an innovative device that greatly outstrips traditional fixed-speed hydropneumatic groups.

ESPA Speedrive's VFD (variable-frequency drive) technology is the fruit of our **E³ (ESPA Efficient Engineering)** innovation programme, a guide for developing integrated quality, based on our culture of permanent improvement in R&D&I.

ESPA Speedrive: a new dimension in pumping

Improved quality in water supply: constant pressure

The most efficient system for adjusting a pump's hydraulic performance to the pressure and flow requirements of supplying water is through the use of **variable-speed** technology. In the case of supplying water to a building that requires a constant pressure regardless of the water flow requested, with a variable-speed system, in addition to improved efficiency, a high-quality, oscillation-free service is obtained, guaranteeing greater durability of the equipment and the installation.

The ESD unit receives a proportional signal from a pressure transducer fitted on the discharge pipeline. The ESD processes this signal and regulates the motor speed in order to keep the pressure constant at the established level, regardless of the variations in flow demand.

With this pump set the pump's operation can be adapted to the different flow demands, constantly setting the consumption that is strictly necessary for the demand at any given moment. The energy consumption will be proportional to the water consumption. In comparison to the same system running at a fixed speed, this translates directly into energy savings.



Performance area with one pump

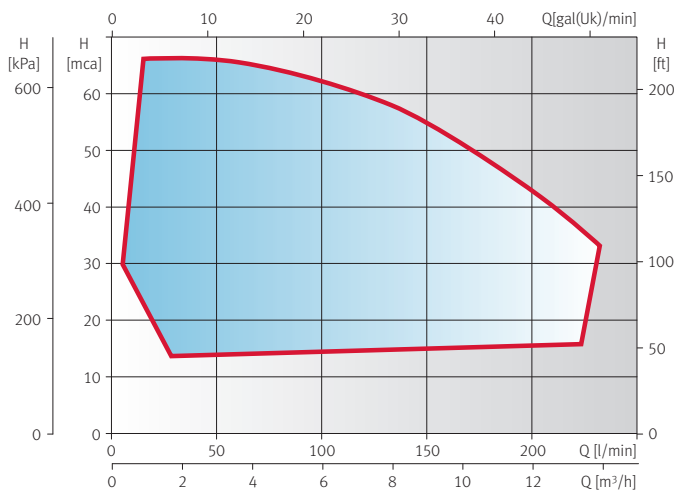

Performance area with sets of 4 pumps in parallel

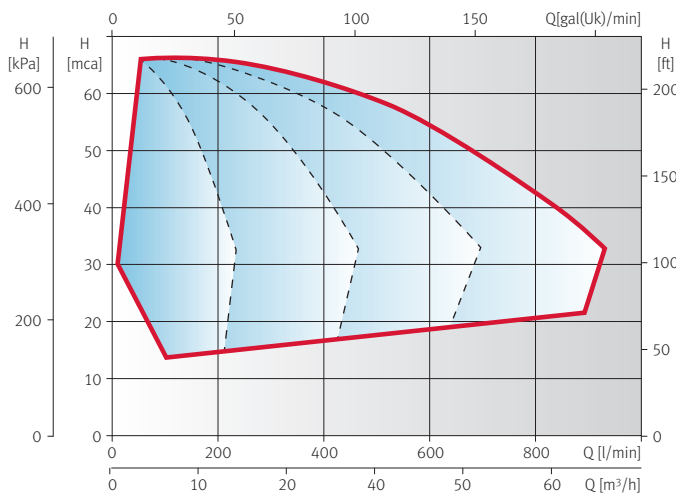

Operating modes

The ESD has a backlit display and a 5-button keypad for displaying the user parameters. The installer can easily regulate and modify the basic operational parameters through the same interface. It also includes a reset option to recover the default factory parameters.

Adjustable operating parameters

- **Language:** options ES, EN, DE, IT, FR.
- **Operation:** AUTOMATIC – MANUAL.
- **Set pressure:** set point.
- **Differential pressure:** hysteresis or difference in the set pressure that marks the start-up of the pump.
- **Maximum motor intensity:** to regulate motor protection.
- **Pump sleep frequency:** sleep frequency; this can be set manually or automatically.

ESD has a system for automatically calculating the pump's sleep frequency on the basis of the specific characteristics of each installation and the set pressure point.

- **Pump stop temporisation**
- **Nominal motor frequency:** 50 Hz – 60 Hz.
- **Motor rotation reversal**
- **ON-OFF auxiliary pump:** auxiliary pump in fixed-speed DOL operation.
- **Auxiliary pump in variable speed mode** by ESD at variable speed.

Configuration in auxiliary pumps

- **Activation frequency:** activation frequency of auxiliary pumps.
- Auxiliary pump activation **temporisation**.
- Auxiliary pump **maximum intensity**.

Parameters displayed

- Set pressure.
- Differential pressure.
- Maximum motor intensity
- Stoppage frequency.
- Pump stop temporisation.
- Module temperature.
- Alarm display: power surge, short-circuit, power failure and module temperature.
- Operational register: number of start-ups, hours in operation and hours online.

Access to advanced parameter settings, the deletion of the operational register and of the alarm history is password protected.

Electronic circuit

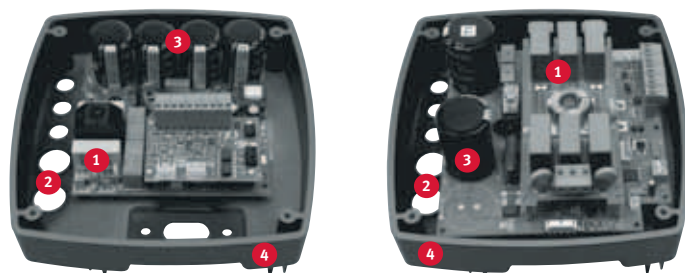

Speedrive M1

Speedrive T2

- 1 EMC filter
- 2 Input/output for cables
- 3 Power circuit
- 4 Aluminium radiator body

Pressure transducer



Device for digital pressure reading

Dimensions and weights

Model	A	B	C	D	Kg
Speedrive M1	128	71	207	207	2
Speedrive M2	128	71	207	207	2,2
Speedrive T1	142	85	207	207	2,2
Speedrive T2	142	85	207	207	2,4
Speedrive T3	142	85	207	207	2,5

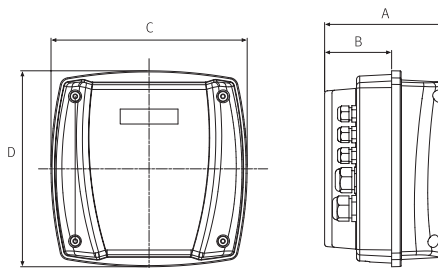

Technical specifications - 50/60 Hz

Description	Single-phase	Three-phase
	M1 - M2	T1 - T2 - T3
Configuration	Built into the junction box	Built into the junction box
Power	230 V, single-phase	400 V, three-phase
Motor voltage	230 V, three-phase	400 V, three-phase
Maximum intensity	5 / 7 A	4 / 6 / 9 A
Cooling	Air-cooled	Air-cooled
Constant pressure	Yes	Yes
Constant flow	Programmable	Programmable
Second duty point	Programmable	Programmable
Dry running protection	Yes	Yes
Pressure transducer	External, 4-20 mA	External, 4-20 mA
Additional digital input	1	1
Additional analogical input	1	1
Level switch terminal	Yes	Yes
PTC	Optional	Optional
External communication port	RS 485	RS 485
Screen	Backlit	Backlit
Auxiliary relay	1 for external alarm	No
Minimum working frequency	Adjustable	Adjustable
Acceleration ramp	1 fixed	1 fixed
Deceleration ramp	1 fixed	1 fixed
Stop temporisation	Yes	Yes
Maximum No. of pumps	Up to 4	Up to 4
Maximum No. of slave pumps (fixed speed)	Up to 3	Up to 3

Energy saving

Electric motors account for 70 % of the energy used worldwide. Of these, 35 % are used to power hydraulic pumps. It could be said that 25 % of world electrical consumption is used to pump fluids. The introduction of VFD technologies has the potential to **save up to 50 %** of this energy.

Conventional flow control methods, using fixed-speed pressurisation, involve recirculating part of the flow via a **by-pass**, or restricting the flow with valves. These systems waste an enormous amount of energy: fixed-speed groups operate at maximum energy consumption whenever they operate independently of the flow demand required at each instant.

Variable-speed systems **regulate energy consumption on the basis of the flow demand** (Fig. 1). They are undoubtedly the most efficient and reliable systems for adjusting the hydraulic performance of pumps to variable demand in flow. In addition, a group controlled by **Speedrive** makes installation easier, as it does away with the need for mechanical flow regulation systems and for large hydropneumatic tanks.

A **Speedrive**-controlled pressurisation system provides added convenience in water supply, **reducing the noise level and eliminating vibrations and water hammers** during the start-up and shutdown cycles. The motor always starts up at low speed, thus **eliminating peaks of high consumption** due to the acceleration of the motor.

The reduction in speed gives rise to new efficiency curves, which run below the maximum speed curve, virtually parallel to it; nonetheless, the curves flatten out, since their height is reduced in a proportion great than that of the flow.

Another highly important aspect is that performance at equivalent points is maintained at different speeds (speed reductions of up to 50 % on the maximum velocity), thus achieving lower consumption while maintaining optimal efficiency.

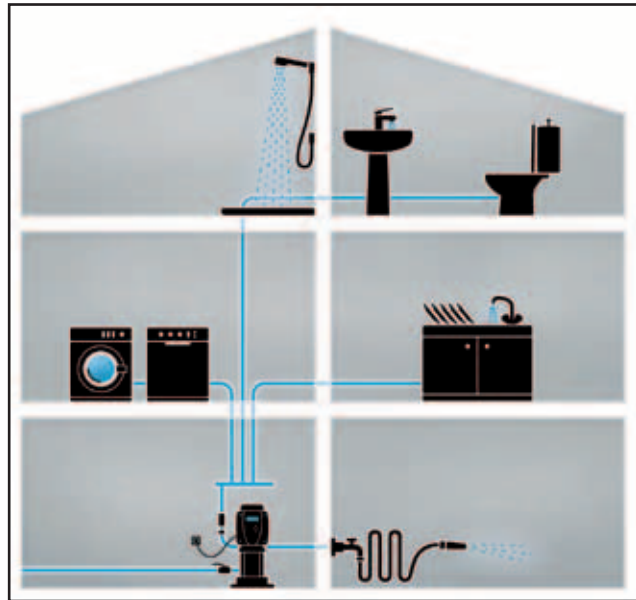

(Fig. 1)

Differential of energy consumption in pumps with VFD

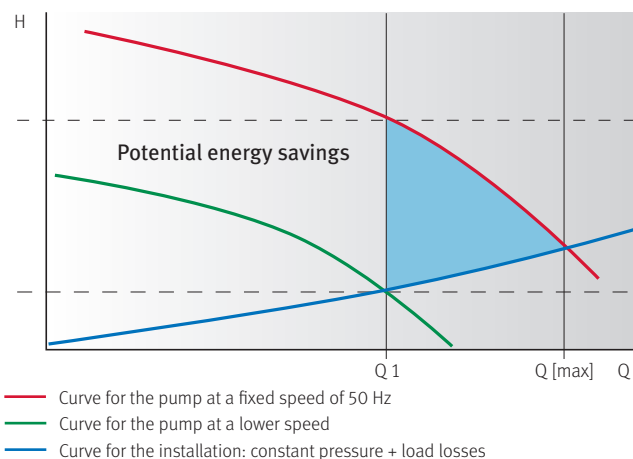

Configuration

The ESPA Speedrive (ESD) variable-frequency driver has been designed to be integrated with the following ESPA pumps: **MULTI-ESD, PRISMA-ESD and XVM-ESD**. With this electronic unit (employing advanced VFD technology) the pump and driver set extends the hydraulic range for each model, guaranteeing efficient service at each point in the performance area, beyond working at one point on a curve.

The ESD module can be adapted to the three-phase motors of these ESPA pumps, **even in existing installations**, thus improving the service quality and extending the unit's performance range. What is more, the large accumulation tank, needed for fixed speed operation, can be replaced by a small expansion vessel. The variable-speed system **does away with fluctuations in the water flow**.

Control comparison with and without VFD

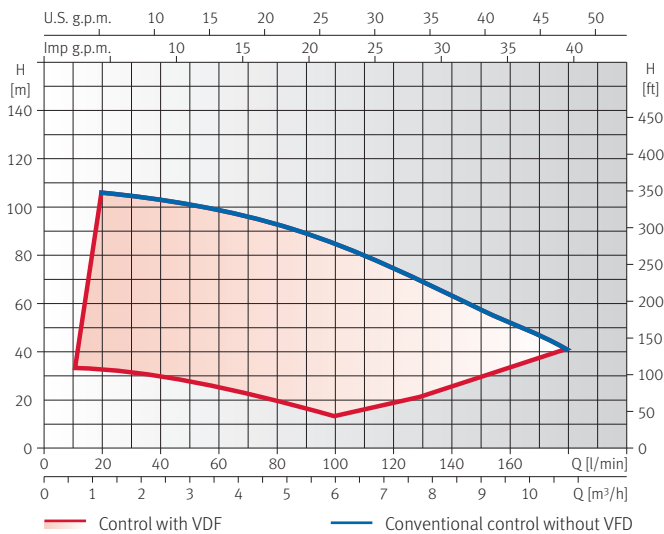

CKE2 MULTI



CKE1 PRISMA 35 6



CKE1 MULTI 35 6



CKE1 XVM 4 13

Dimensions and weights

Model	Max. height	Length	Width	Kg
CKE1 PRISMA 35 6	505	207	310	27,3

Dimensions and weights

Model	Max. height	Length	Width	Kg
CKE1 MULTI 35 6	505	207	310	27,3

Dimensions and weights

Model	Max. height	Length	Width	Kg
CKE2 MULTI 35 6	1040	600	440	58

Pumps with ESD in pressure groups

The ESD modules can control the operation of pressure booster sets up to 4 pumps.
The ESD modules can control the operation of pressure into two different manners:

1. Units with one single ESD module:

- CKED 2 pumps: variable-speed main pump + fixed-speed DOL auxiliary pump.
- CKED 3 pumps: variable-speed main pump + 2 fixed-speed randomly alternating DOL auxiliary pumps.
- CKED 4 pumps: variable-speed main pump + 3 fixed-speed randomly alternating DOL auxiliary pumps.



CKED MULTI



1 single ESD regulating the service pump and operating up to 3 auxiliary pumps in DOL start-up. Configuration of the master pump operating at variable speeds and 3 auxiliary pumps with in cascade operation start-up for greater flow demands. Random alternation in the start-up of the auxiliary pumps.

2. Units with multiple ESD modules (up to 4):

- CKE2: 2 pumps: variable-speed main pump+variable-speed auxiliary pump, both operating in cyclical duty changeover.
- CKE3: 3 pumps: variable-speed main pump + 2 variable-speed auxiliary pumps, all 3 operating in cyclical duty changeover.
- CKE4: 4 pumps: variable-speed main pump + 3 variable-speed auxiliary pumps, all 4 operating in cyclical duty changeover.



CKE4 MULTI



A pump set of up to 4 pumps controlled by 4 ESDs.
Configuration of service pumps and back-up pumps, all regulated.
Random alternation between the 4 pumps at each system start-up.
Once the auxiliary pumps come into operation, all the regulated pumps operate in synchronisation at the same frequency.
This operational mode enhances the effectiveness of the pump set and cuts down on the start-up and shutdown cycle for pumps.



CKE2 XVM

Model ESD	Input	Output		Dimensions		Weight (kg)
	Power source voltage (V)	Max. motor current (A)	Motor voltage (V)	A (mm)	B (mm)	
M1	1~230 V AC ± 10 %	5	3~230 V AC	128	71	2,0
M2		7				2,2
T1	3~400 V AC ± 10 %	4	3~400 V AC	142	85	2,2
T2		6				2,4
T3		9				2,5

Operating conditions:

- IP 55 protection.
- Maximum ambient temperature: 40 °C.
- For M1 and M2: 1 free, maximum intensity power contact. 2 A, 1~230 V AC.
- Digital input for 4-20 mA transducer with 24-V DC power source.
- Auxiliary transducer input.
- Digital input for the external level switch, or -free volt- contact to switch the circuit on and off.
- Communication between ESD modules RS 485 serial port (up to 4 ESDs).

Construction

Pressure boosting sets with automatic operation and constant pressure, consisting of variable speed pump (s) driven by SPEEDRIVE frequency converter, with isolation and non-return valves, pressure gauge, analog sensors, and start/stop control kit in multi-pump versions.

Designation

VSR - SPEEDRIVE 3 / MXV-B32-407

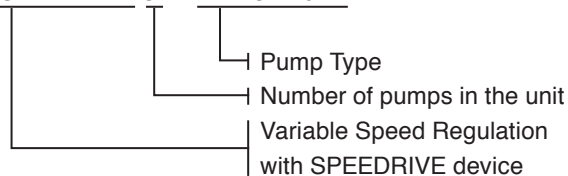

Operation

Pumps are directly driven by SPEEDRIVE frequency converters. According to the water consumption, the pumps at variable speed ensures the required water quantity at the set pressure.

Pumps start in a cascade sequence, with changeover of pump starting sequence.

SPEEDRIVE frequency converter for regulating three-phase motors for operation at constant pressure. Attached directly to the motor connection box. Air-cooled. Options for operation in pump groups of up to 3 units controlled from a single SPEEDRIVE or in communication with 3 speeddrives.

Only two parameters to set at starting;

- Maximum motor current
- Working pressure

Possibility to display;

- Pressure of the system
- Working frequency
- Absorbed current
- Alarms



Possibility to arrange and set;

- Constant flow
- 2nd work point
- Dry operation protection
- External communication port (RS 485)
- Stop time
- Auxiliary relay configuration

Applications

- Water supply
- Sprinkling
- Irrigation and spraying
- Pumping water from wells and out of low-lying tanks.

Pump Models and Capacities

Technical Data

- Mains connections 1~230V/50 Hz/3~400V/50 Hz
- Suction head max 5 m
- Inlet pressure max 4 bar
- Fluid temperature +5 °C to +110 °C
- Operating pressure max 12 bar
- Analog sensor 4-20 mA
- Protection class IP54

Motors

- 2-pole induction motors, 50 Hz, n=2900 rpm
- Three-phase 230/400V ± %10
- Insulation class F
- Protection IP54
- Constructed in accordance with IEC 60034
- Other voltages and frequencies on request.

Peripheral Pumps		Q (m³/h)									
		0	1	2	3	4					
MXV-B 25 204	H(m)	0	42	38	30	22					
MXV-B 25 205		0	52	48	38	26					
MXV-B 25 206		0	62	56	44	32					
MXV-B 25 207		0	76	64	54	44					
MXV-B 25 208		0	84	75	62	45					
MXV-B 25 210		0	105	94	78	56					

Self-priming Pumps		Q (m³/h)									
		3	4	5	6	7	8				
MXV-B 32-404	H(m)	40	38	34	28	22	16				
MXV-B 32-405		50	46	42	34	26	20				
MXV-B 32-406		60	57	50	42	32	24				
MXV-B 32-407		70	65	58	50	40	30				
MXV-B 32-408/A		80	75	64	54	44	32				
MXV-B 32-410/A		100	90	82	70	56	40				

Self-priming Pumps		Q (m³/h)									
		5	6	7	8	9	10	11	12		
MXV-B 40-804	H(m)	44	42	40	38	36	36	30	28		
MXV-B 40-805/A		54	52	50	48	44	42	38	36		
MXV-B 40-806/A		64	62	60	58	56	50	44	38		
MXV-B 40-807/A		76	74	72	70	66	60	52	48		
MXV-B 40-808/A		88	86	84	80	76	68	60	50		
MXV-B 40-810/A		110	108	106	100	94	84	82	70		

Self-priming Pumps		Q (m³/h)									
		1	2	3	4	5	6	7	8	9	10
MULTI 35 5 N	H(m)	65	64	60	58	62	42	38	30	24	18
MULTI 35 6 N		82	80	76	62	66	60	52	52	36	26
MULTI 35 8 N		118	104	102	96	90	84	72	72	52	40
MULTI 35 10 N		135	130	126	120	112	104	94	80	70	54

Self-priming Pumps		Q (m³/h)									
		2	4	6	8	10	12	14	16	18	
MULTI 55 6 N	H(m)	75	72	68	62	58	52	46	40	30	
MULTI 55 7 N		88	84	78	72	66	62	54	52	35	

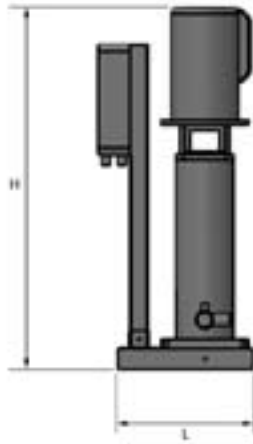

Model	DNs	DNd	W	L	H
VSR-SPEEDRIVE 1 / MXV-B 25 204	1"	1"	470	400	760
VSR-SPEEDRIVE 1 / MXV-B 25 205	1"	1"	470	400	760
VSR-SPEEDRIVE 1 / MXV-B 25 206	1"	1"	470	400	1060
VSR-SPEEDRIVE 1 / MXV-B 25 207	1"	1"	470	400	1060
VSR-SPEEDRIVE 1 / MXV-B 25 208	1"	1"	470	400	1060
VSR-SPEEDRIVE 1 / MXV-B 25 210	1"	1"	470	400	1060
VSR-SPEEDRIVE 1 / MXV-B 32-404	1¼"	1¼"	470	420	800
VSR-SPEEDRIVE 1 / MXV-B 32-405	1¼"	1¼"	470	420	800
VSR-SPEEDRIVE 1 / MXV-B 32-406	1¼"	1¼"	470	420	800
VSR-SPEEDRIVE 1 / MXV-B 32-407	1¼"	1¼"	470	420	800
VSR-SPEEDRIVE 1 / MXV-B 32-408/A	1¼"	1¼"	470	420	950
VSR-SPEEDRIVE 1 / MXV-B 32-410/A	1¼"	1¼"	470	420	950
VSR-SPEEDRIVE 1 / MXV-B 40-804	1½"	1½"	470	470	950
VSR-SPEEDRIVE 1 / MXV-B 40-805/A	1½"	1½"	470	470	950
VSR-SPEEDRIVE 1 / MXV-B 40-806/A	1½"	1½"	470	470	950
VSR-SPEEDRIVE 1 / MXV-B 40-807/A	1½"	1½"	470	470	950
VSR-SPEEDRIVE 1 / MXV-B 40-808/A	1½"	1½"	470	470	950
VSR-SPEEDRIVE 1 / MXV-B 40-810/A	1½"	1½"	470	470	1100
VSR-SPEEDRIVE 1 / MULTI 35 5 N	1½"	1¼"	470	500	760
VSR-SPEEDRIVE 1 / MULTI 35 6 N	1½"	1¼"	470	500	760
VSR-SPEEDRIVE 1 / MULTI 35 8 N	1½"	1¼"	470	500	760
VSR-SPEEDRIVE 1 / MULTI 35 10 N	1½"	1¼"	470	500	950
VSR-SPEEDRIVE 1 / MULTI 55 6 N	1½"	1¼"	470	500	950
VSR-SPEEDRIVE 1 / MULTI 55 7 N	1½"	1¼"	470	500	950

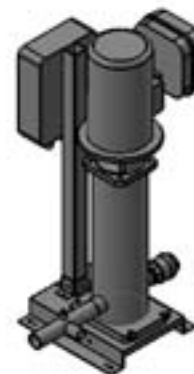

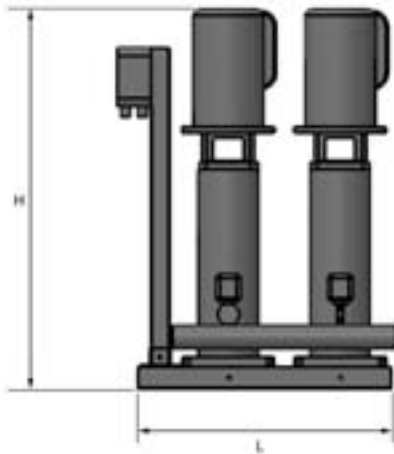

Model	DNs	DNd	W	L	H
VSR-SPEEDRIVE 2 / MXV-B 25 204	1½"	1½"	780	700	760
VSR-SPEEDRIVE 2 / MXV-B 25 205	1½"	1½"	780	700	760
VSR-SPEEDRIVE 2 / MXV-B 25 206	1½"	1½"	780	700	1060
VSR-SPEEDRIVE 2 / MXV-B 25 207	1½"	1½"	780	700	1060
VSR-SPEEDRIVE 2 / MXV-B 25 208	1½"	1½"	780	700	1060
VSR-SPEEDRIVE 2 / MXV-B 25 210	1½"	1½"	780	700	1060
VSR-SPEEDRIVE 2 / MXV-B 32-404	2"	2"	780	700	800
VSR-SPEEDRIVE 2 / MXV-B 32-405	2"	2"	780	700	800
VSR-SPEEDRIVE 2 / MXV-B 32-406	2"	2"	780	700	800
VSR-SPEEDRIVE 2 / MXV-B 32-407	2"	2"	780	700	950
VSR-SPEEDRIVE 2 / MXV-B 32-408/A	2"	2"	780	700	1200
VSR-SPEEDRIVE 2 / MXV-B 32-410/A	2"	2"	780	700	1200
VSR-SPEEDRIVE 2 / MXV-B 40-804	2"	2"	780	700	950
VSR-SPEEDRIVE 2 / MXV-B 40-805/A	2"	2"	780	700	950
VSR-SPEEDRIVE 2 / MXV-B 40-806/A	2"	2"	780	700	950
VSR-SPEEDRIVE 2 / MXV-B 40-807/A	2"	2"	780	700	950
VSR-SPEEDRIVE 2 / MXV-B 40-808/A	2"	2"	780	700	950
VSR-SPEEDRIVE 2 / MXV-B 40-810/A	2"	2"	780	700	1100
VSR-SPEEDRIVE 2 / MULTI 35 5 N	2"	2"	780	660	760
VSR-SPEEDRIVE 2 / MULTI 35 6 N	2"	2"	780	660	760
VSR-SPEEDRIVE 2 / MULTI 35 8 N	2"	2"	780	660	760
VSR-SPEEDRIVE 2 / MULTI 35 10 N	2"	2"	780	660	950
VSR-SPEEDRIVE 2 / MULTI 55 6 N	2"	2"	780	660	950
VSR-SPEEDRIVE 2 / MULTI 55 7 N	2"	2"	780	660	950

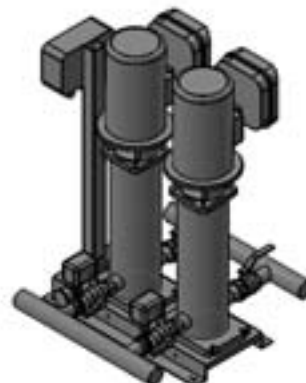
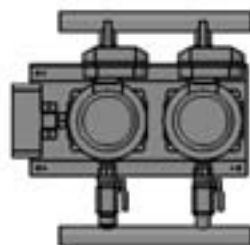

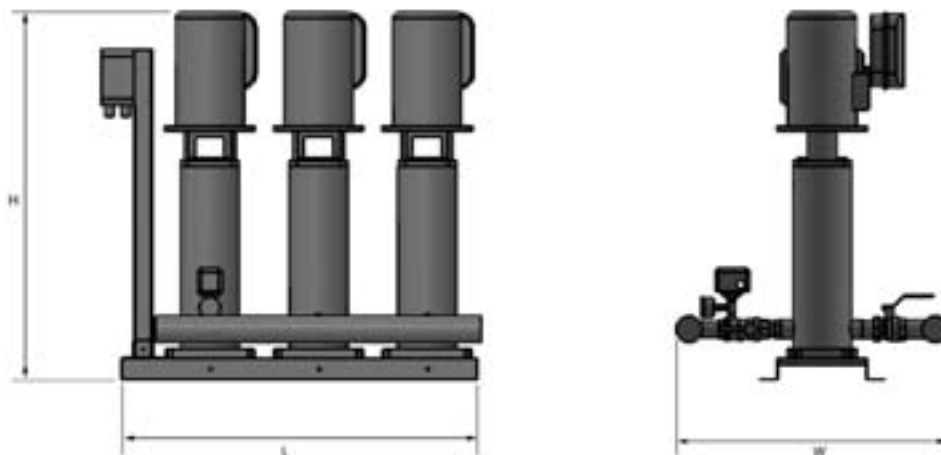

Model	DNs	DNd	W	L	H
VSR-SPEEDRIVE 3 / MXV-B 25 204	2"	2"	1080	700	1060
VSR-SPEEDRIVE 3 / MXV-B 25 205	2"	2"	1080	700	1060
VSR-SPEEDRIVE 3 / MXV-B 25 206	2"	2"	1080	700	1060
VSR-SPEEDRIVE 3 / MXV-B 25 207	2"	2"	1080	700	1060
VSR-SPEEDRIVE 3 / MXV-B 25 208	2"	2"	1080	700	1060
VSR-SPEEDRIVE 3 / MXV-B 25 210	2"	2"	1080	700	1060
VSR-SPEEDRIVE 3 / MXV-B 32-404	2"	2"	1080	700	950
VSR-SPEEDRIVE 3 / MXV-B 32-405	2"	2"	1080	700	950
VSR-SPEEDRIVE 3 / MXV-B 32-406	2"	2"	1080	700	950
VSR-SPEEDRIVE 3 / MXV-B 32-407	2"	2"	1080	700	950
VSR-SPEEDRIVE 3 / MXV-B 32-408/A	2"	2"	1080	700	950
VSR-SPEEDRIVE 3 / MXV-B 32-410/A	2"	2"	1080	700	950
VSR-SPEEDRIVE 3 / MXV-B 40-804	2½"	2½"	1080	750	950
VSR-SPEEDRIVE 3 / MXV-B 40-805/A	2½"	2½"	1080	750	950
VSR-SPEEDRIVE 3 / MXV-B 40-806/A	2½"	2½"	1080	750	950
VSR-SPEEDRIVE 3 / MXV-B 40-807/A	2½"	2½"	1080	750	950
VSR-SPEEDRIVE 3 / MXV-B 40-808/A	2½"	2½"	1080	750	1100
VSR-SPEEDRIVE 3 / MXV-B 40-810/A	2½"	2½"	1080	750	1250
VSR-SPEEDRIVE 3 / MULTI 35 5 N	2½"	2"	1080	660	950
VSR-SPEEDRIVE 3 / MULTI 35 6 N	2½"	2"	1080	660	950
VSR-SPEEDRIVE 3 / MULTI 35 8 N	2½"	2"	1080	660	950
VSR-SPEEDRIVE 3 / MULTI 35 10 N	2½"	2"	1080	660	950
VSR-SPEEDRIVE 3 / MULTI 55 6 N	2½"	2"	1080	660	950
VSR-SPEEDRIVE 3 / MULTI 55 7 N	2½"	2"	1080	660	950

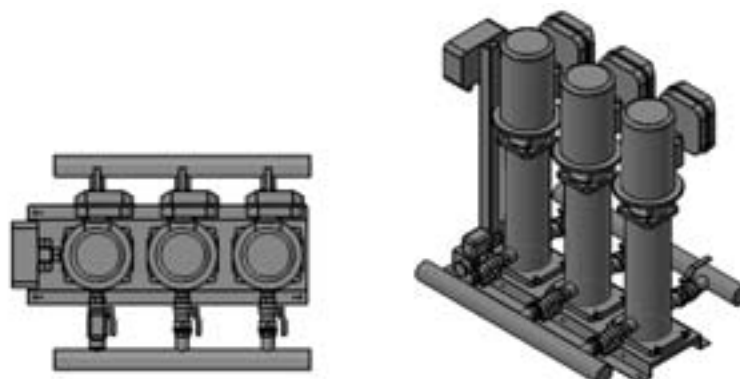

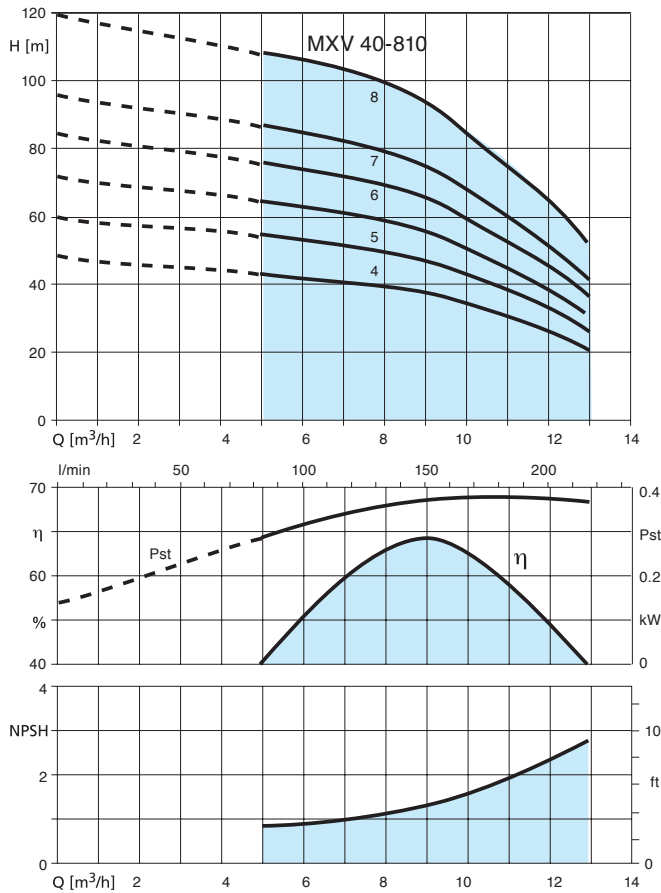
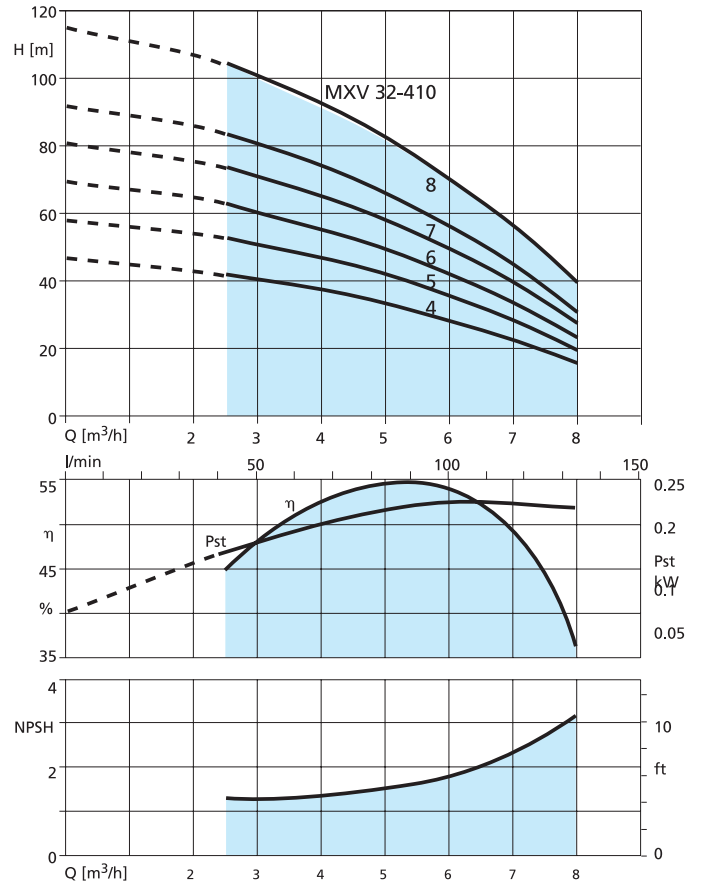
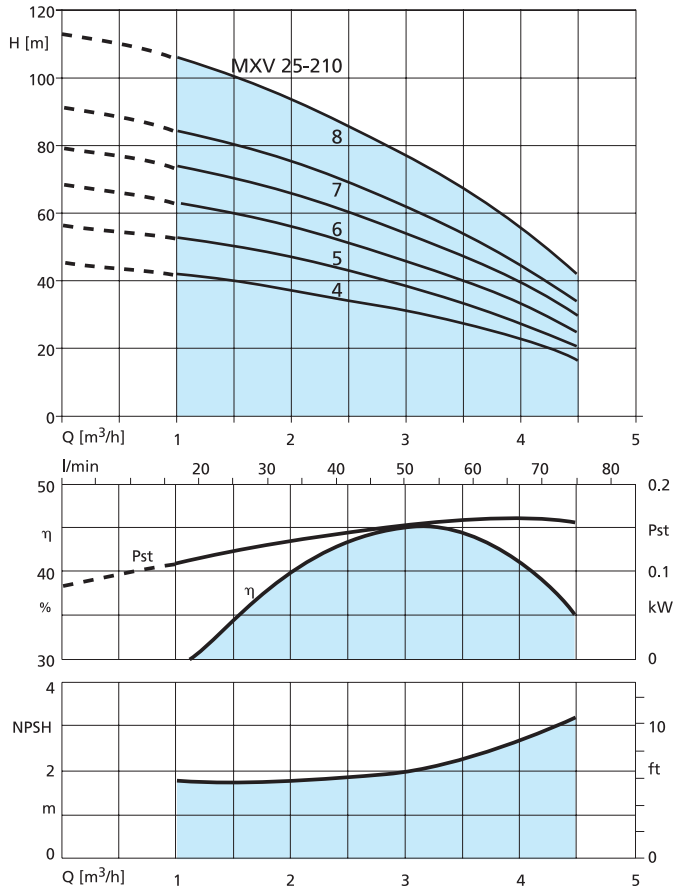

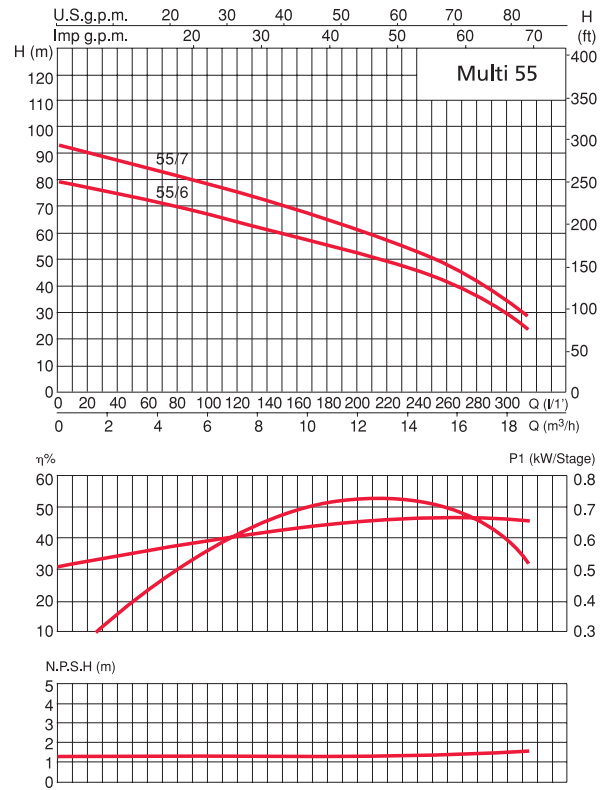
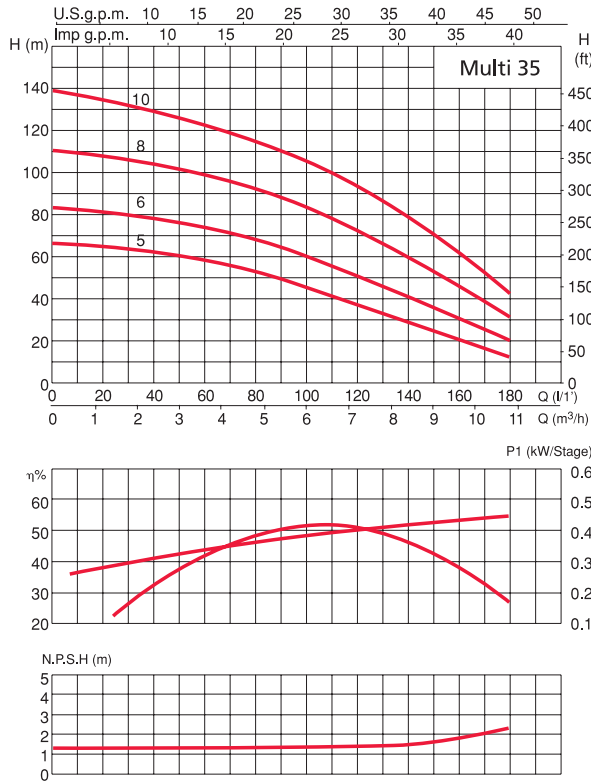

Operation

According to the pressure decrease in the system, the control panel, with electronic card, manages the pump operation, and it stops the system when there is no water in the tank.

Pump start with a signal from the pressure switch.

New electrical control panel for pressurisation units, all with electronic card with microprocessors, for managing pump operation. The microprocessor carries out continuous secure checks during all the various work phases of the pump and incorporates all necessary functions, thus reducing electrical and electronic components inside the panel.

In particular:

- pump starting according to water demand.
- pump stop when there is no water in the suction.

Maximum clarity for all signals

The status of the unit can easily be identified on the front of the electronic card with the following signals:

- Power on led.
- No water led.
- Failure led
- Pump running led

Maximum simplicity of control

The front of electronic card features the following signals and controls:

- AUT-STOP-MAN button
- RESET push-button.



Construction

Pressure boosting sets with automatic operation, consisting of a pump on a baseplate, with suction and delivery isolation and non-return valves, pressure switch, pressure gauge and control panel.

Motors

2-pole induction motors, 50 Hz, n = 2900 rpm.

Three-phase 400 V ± 10%

Insulation class F.

Protection IP 54.

Constructed in accordance with: IEC 60034.

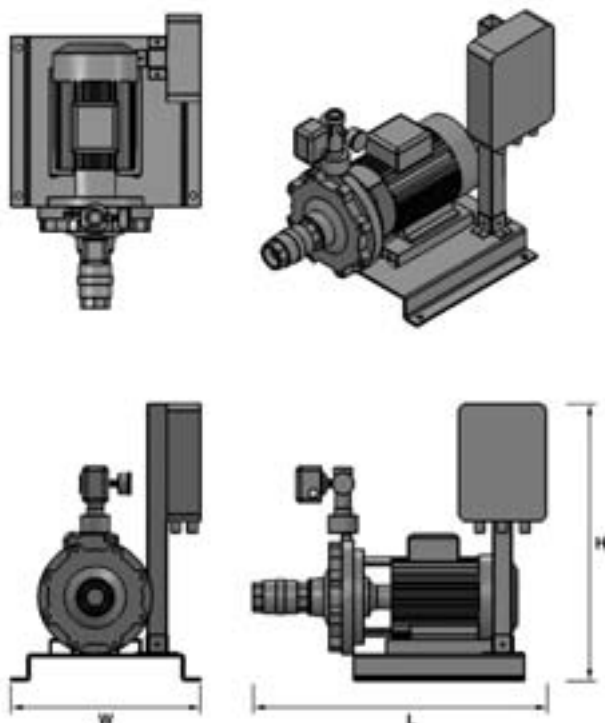

Model	DNs	DNd	H	L	W
DC1 NMD 20/110 AE	1 1/4"	1"	650	250	300
DC1 NMD 20/110 BE	1 1/4"	1"	650	250	300
DC1 NMD 20/110 ZE	1 1/4"	1"	650	250	300
DC1 NMD 20/140 AE	1 1/4"	1"	650	330	300
DC1 NMD 20/140 BE	1 1/4"	1"	650	330	300
DC1 NMD 25/190 AE	1 1/2"	1"	650	350	300
DC1 NMD 25/190 BE	1 1/2"	1"	650	350	300
DC1 NMD 25/190 CE	1 1/2"	1"	650	350	300
DC1 NMD 32/210 AE	2"	1 1/4"	650	515	300
DC1 NMD 32/210 BE	2"	1 1/4"	650	440	300
DC1 NMD 32/210 CE	2"	1 1/4"	650	440	300
DC1 NMD 32/210 DE	2"	1 1/4"	650	420	300
DC1 NMD 40/180 AE	2"	1 1/2"	650	515	300
DC1 NMD 40/180 BE	2"	1 1/2"	650	440	300
DC1 NMD 40/180 CE	2"	1 1/2"	650	440	300
DC1 NMD 40/180 DE	2"	1 1/2"	650	420	300

Operation

According to the pressure decrease in the system, the control panel, with electronic card, manages the pump operation, the changeover of pump starting sequence and it stops the system when there is no water in the tank.

Pumps starting in a cascade sequence, with a signal from the pressure switches.

New electrical control panels for pressurisation units, all with electronic card with microprocessors, for managing pump operation. The microprocessor carries out continuous secure checks during all the various work phases of the pumps and incorporates all necessary functions, thus reducing electrical and electronic components inside the panel.

In particular:

- pumps starting in a cascade sequence according to water demand.
- changeover of pump starting sequence.
- pumps stop when there is no water in the suction.

Maximum clarity for all signals

The status of the unit can easily be identified on the front of the electronic card with the following signals:

- Power on led.
- No water led.
- Failure led (1 for each pump).
- Pump running led (1 for each pump).

Maximum simplicity of control

The front of electronic card features the following signals and controls:

- AUT-STOP-MAN button (1 for each pump)
- RESET push-button.

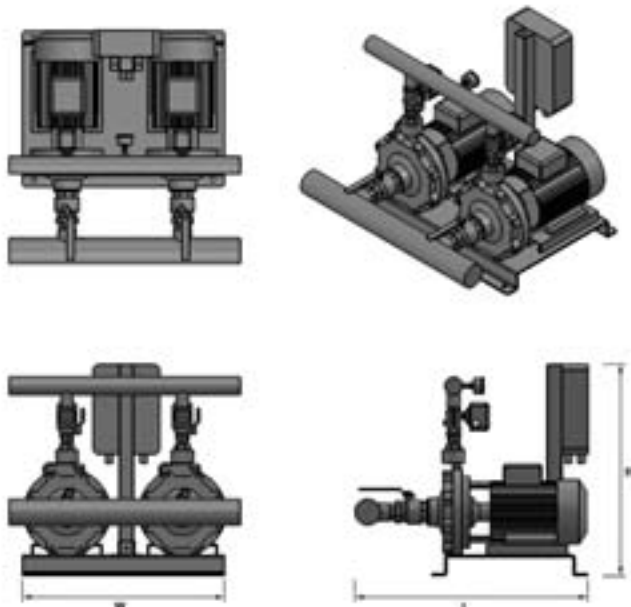

Construction

Pressure boosting sets with automatic operation, consisting of 2 pumps on a common baseplate, with suction and delivery manifolds, isolation and non-return valves, pressure switches, pressure gauge and control panel.

Suction and delivery manifolds are in AISI 304 stainless steel.

The unit includes one pressure gauge and two adjustable differential pressure switches.

Motors

2-pole induction motors, 50 Hz, n = 2900 rpm.

Single-phase 230 V ± 10%, with thermal protector.

Insulation class F.

Protection IP 54.

Constructed in accordance with: IEC 60034.

Model	DNs	DNd	H	L	W
DC2 NMD 20/110 AE	2"	1 1/4"	800	250	600
DC2 NMD 20/110 BE	2"	1 1/4"	800	250	600
DC2 NMD 20/110 ZE	2"	1 1/4"	800	250	600
DC2 NMD 20/140 AE	2"	1 1/4"	800	267	600
DC2 NMD 20/140 BE	2"	1 1/4"	800	267	600
DC2 NMD 25/190 AE	2"	1 1/4"	800	347	600
DC2 NMD 25/190 BE	2"	1 1/4"	800	347	600
DC2 NMD 25/190 CE	2"	1 1/4"	800	347	600
DC2 NMD 32/210 AE	DN 80	2"	800	390	800
DC2 NMD 32/210 BE	DN 80	2"	800	390	800
DC2 NMD 32/210 CE	DN 80	2"	800	390	800
DC2 NMD 32/210 DE	DN 80	2"	800	390	800
DC2 NMD 40/180 AE	DN 80	2"	800	415	800
DC2 NMD 40/180 BE	DN 80	2"	800	415	800
DC2 NMD 40/180 CE	DN 80	2"	800	415	800
DC2 NMD 40/180 DE	DN 80	2"	800	415	800

Operation

According to the pressure decrease in the system, the control panel, with electronic card, manages the pump operation, the changeover of pump starting sequence and it stops the system when there is no water in the tank.

Pumps starting in a cascade sequence, with a signal from the pressure switches.

New electrical control panels for pressurisation units, all with electronic card with microprocessors, for managing pump operation. The microprocessor carries out continuous secure checks during all the various work phases of the pumps and incorporates all necessary functions, thus reducing electrical and electronic components inside the panel.

In particular:

- pumps starting in a cascade sequence according to water demand.
- changeover of pump starting sequence.
- pumps stop when there is no water in the suction.

Maximum clarity for all signals

The status of the unit can easily be identified on the front of the electronic card with the following signals:

- Power on led.
- No water led.
- Failure led (1 for each pump).
- Pump running led (1 for each pump).

Maximum simplicity of control

The front of electronic card features the following signals and controls:

- AUT-STOP-MAN button (1 for each pump)
- RESET push-button.

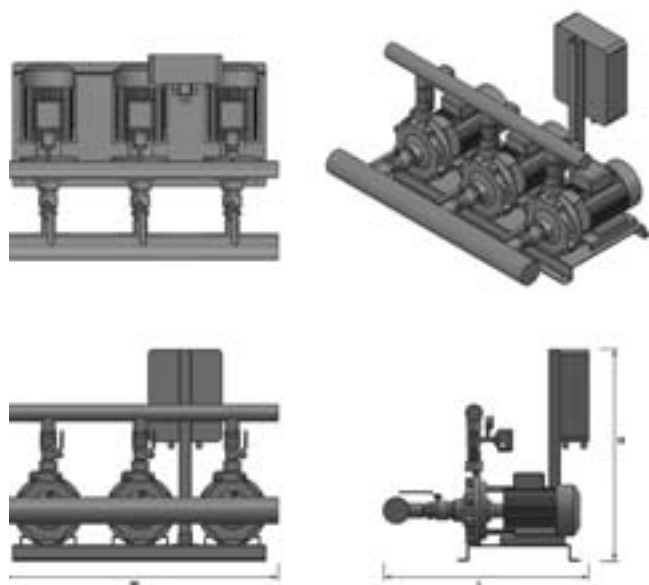

Construction

Pressure boosting sets with automatic operation, consisting of 3 pumps on a common baseplate, with suction and delivery manifolds, isolation and non-return valves, pressure switches, pressure gauge and control panel.

Suction and delivery manifolds are in AISI 304 stainless steel.

The unit includes one pressure gauge and two adjustable differential pressure switches.

Motors

2-pole induction motors, 50 Hz, n = 2900 rpm.

Single-phase 230 V ± 10%, with thermal protector.

Insulation class F.

Protection IP 54.

Constructed in accordance with: IEC 60034.

Model	DNs	DNd	H	L	W
DC3 NMD 20/110 AE	2"	1 1/2"	800	500	900
DC3 NMD 20/110 BE	2"	1 1/2"	800	500	900
DC3 NMD 20/110 ZE	2"	1 1/2"	800	500	900
DC3 NMD 20/140 AE	2"	1 1/2"	800	597	900
DC3 NMD 20/140 BE	2"	1 1/2"	800	597	900
DC3 NMD 25/190 AE	2"	1 1/2"	800	760	900
DC3 NMD 25/190 BE	2"	1 1/2"	800	760	900
DC3 NMD 25/190 CE	2"	1 1/2"	800	707	900
DC3 NMD 32/210 AE	DN 100	2"	800	905	1200
DC3 NMD 32/210 BE	DN 100	2"	800	830	1200
DC3 NMD 32/210 CE	DN 100	2"	800	830	1200
DC3 NMD 32/210 DE	DN 100	2"	800	810	1200
DC3 NMD 40/180 AE	DN 100	2 1/2"	800	946	1200
DC3 NMD 40/180 BE	DN 100	2 1/2"	800	871	1200
DC3 NMD 40/180 CE	DN 100	2 1/2"	800	871	1200
DC3 NMD 40/180 DE	DN 100	2 1/2"	800	851	1200

		Q(m³/h)							
		0	2	4	6	8	10	12	14
NMD 20/110 AE	H(m)	0	38	26					
NMD 20/110 BE		0	28						
NMD 20/110 ZE		0	32	20					
NMD 20/140 AE		0	64	56	46				
NMD 20/140 BE		0	50	47	34				
NMD 25/190 AE		0	98	95	90	82			
NMD 25/190 BE		0	77	73	66	57			
NMD 25/190 CE		0	63	58	52	40			
NMD 32/210 AE		0	118	116	113	107	105	103	
NMD 32/210 BE		0	108	106	103	96	95	91	
NMD 32/210 CE		0	87	85	83	77	75	72	
NMD 32/210 DE		0	79	74	70	60	57	52	
NMD 40/180 AE		0	94	95	95	93	92	91	90
NMD 40/180 BE		0	88	90	89	86	85	83	82
NMD 40/180 CE		0	70	72	70	67	67	65	64
NMD 40/180 DE		0	62	63	62	58	56	55	53

DC1 / DC2 / DC3 NMD

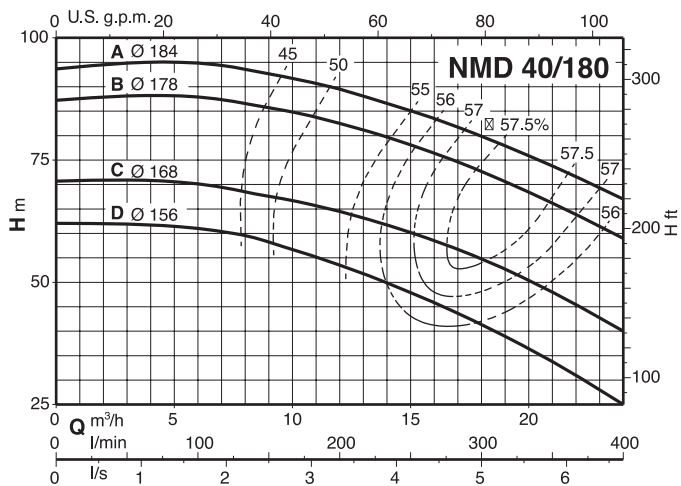
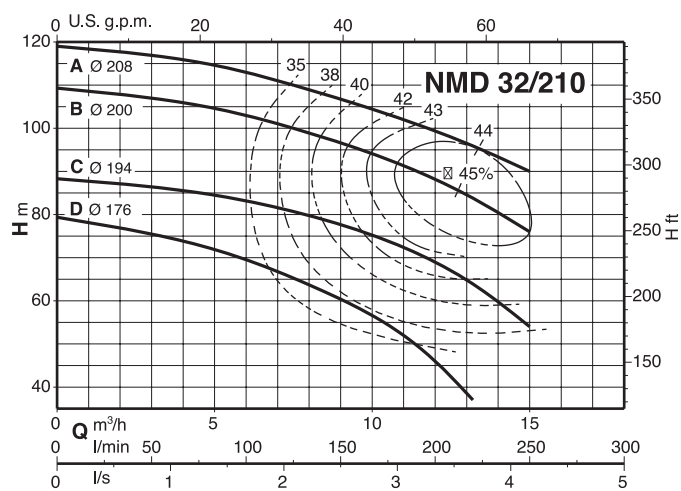
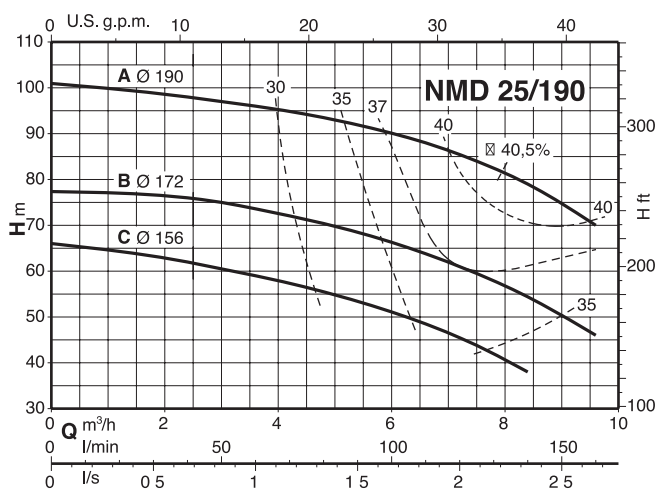
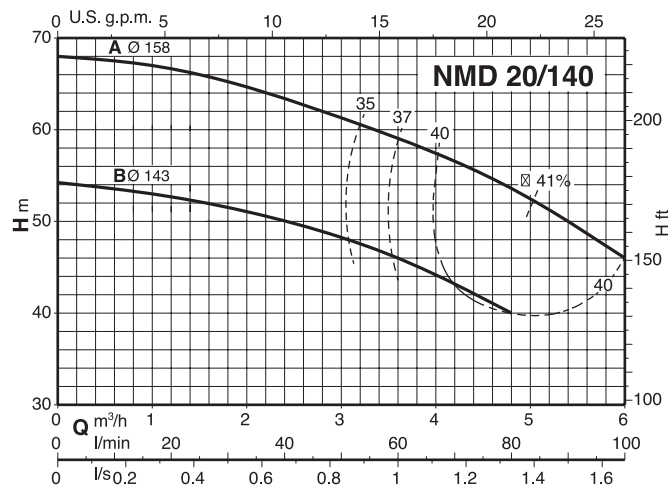
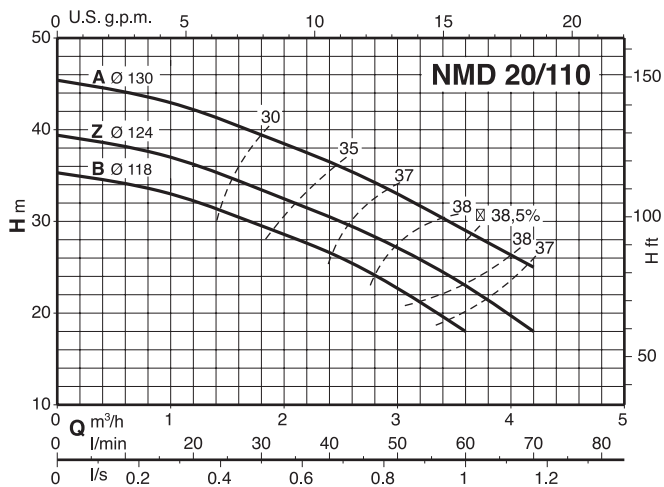

Construction

Pressure boosting sets with automatic operation, consisting of up to 6 pumps on a common baseplate, with suction and delivery valves, and non-return valves, (suction and delivery manifolds in multi-pump units), contact manometer in fixed speed regulation (SDC) units, analog pressure sensor in variable speed regulation (VSR) units, pressure gauge, float switch, special connector in 1-pump configuration, and control panel as fixed speed (SDC), and variable speed (VSR).

Suction and delivery manifolds are in AISI 304, up to DN100 sizes, and electro-galvanized over DN100 sizes.

The unit includes one pressure gauge and adjustable differential pressure regulator as contact manometer in SDC execution, analog pressure sensor in VSR execution.



Applications

- Water supply
- Sprinkling
- Fire fighting
- Irrigation and spraying
- Pumping water from wells and out of low lying tanks.

Technical Data

- Main connection
 - 1 ~ 230 V / 50 Hz,
 - 3 ~ 400 V / 50 Hz,
 - 3 ~ 400 V / 690 V / 50 Hz,
- Suction head max. 5 m
- Inlet pressure max. 8 bar
- Fluid temperature +5°C to 110°C
- Operating pressure max. 25 bar
- Differential pressure regulator, contact manometer, 2-20 bar
- Analog sensor setting range 2-25 bar
- Protection IP54

Motor

2-pole induction motors, 50 Hz, n=2900 rpm
 Three-phase 230/400 V, 400/690 V ±10%
 Insulation class F
 Protection IP54
 Constructed in accordance with IEC 60034
 Other voltages and frequencies on request

Designation

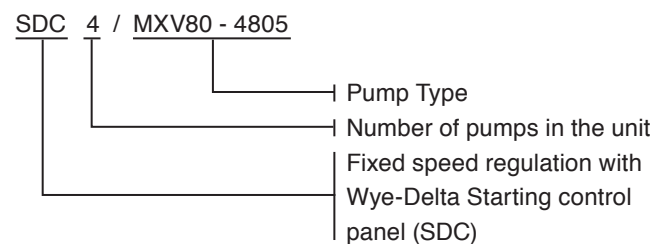
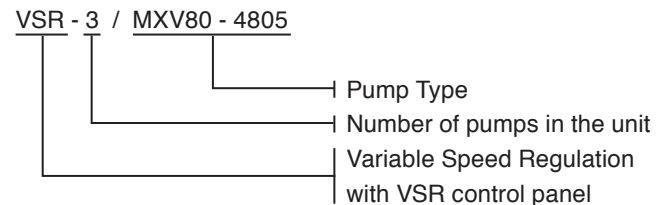

Fixed speed pump units with SDC type control panels

The PLC carries out continuous secure checks during all the various work phases of the pumps and incorporates all necessary functions, thus reducing electrical and electronic components inside the panel.

In particular:

- for use in systems with 1-6 star delta starting pumps.
- pumps starting in a cascade sequence according to water demand.
- changeover of pump starting sequence.
- pumps stop when there is no water in the suction.

Operation

For booster sets made up to two pumps: according to the pressure decrease in the system, the pressure switches make the pumps to start in cascade mode and the starting changeover is made by the PLC.

For sets made of 3, 4, 5, 6 pumps: Operation controlled by a PLC with signal from a contact manometer. The pumps operate with only one pressure setting.



Variable speed pump units with VSR type control panels

These are indispensable in all those cases where constant pressure is required and when high pressure pumps are being controlled.

All the various working phases are managed and controlled by the VSR control panel with PLC, which can operate up to 6 pumps working simultaneously.

Maximum clarity of signals

All the various calibration parameters appear as messages on the display of the controller.

If there are any faults or defects a message appears on the display giving details of the problem.

Constant or increased pressure

All the pumps can work with the same pressure value (set point), or, for systems with high head losses, the set point pressure can be increased depending on volume of flow.

Silent operation

Motors working at reduced speed and check valves that close gradually mean that operation is particularly quiet.

Long life for pumps

All the mechanical components of the pumps and motors are stressed to a minimum, due to the variable speed operation.

Energy savings

The motors consume only the precise level of power necessary moment to moment, in order to supply the quantity of water required by the system.

No more high capacity vessels

The use of inverters means that high capacity pressure vessels and membrane vessels are no longer necessary. Even units with high flowrate pumps only require a small 20 litre membrane vessels.

Great versatility

The great versatility of the controller enables the construction of special units with operational logics different from those of normal pressurisation units, depending on the requirements and characteristics of the systems.

Operation

Depending on water consumption, one or more pumps are activated, the first one at variable speed, in order to guarantee the quantity of water required at the set pressure.

		Q(m³/h)						
		0	1	2	3	4		
MXV-B 25 203	H(m)							
MXV-B 25 204		0	42	38	30	22		
MXV-B 25 205		0	52	48	38	26		
MXV-B 25 206		0	62	56	44	32		
MXV-B 25 207		0	76	64	54	44		
MXV-B 25 208		0	84	75	62	45		
MXV-B 25 210		0	105	94	78	56		
MXV 25-212		0	126	112	92	70		
MXV 25-214		0	150	130	108	78		
MXV 25-216		0	170	150	124	90		
MXV 25-218		0	190	170	140	104		
MXV 25-220		0	214	178	155	114		

		Q(m³/h)							
		3	4	5	6	7	8		
MXV-B 32-403	H(m)								
MXV-B 32-404		40	38	34	28	22	16		
MXV-B 32-405		50	46	42	34	26	20		
MXV-B 32-406		60	57	50	42	32	24		
MXV-B 32-407		70	65	58	50	40	30		
MXV-B 32-408/A		80	75	64	54	44	32		
MXV-B 32-410/A		100	90	82	70	56	40		
MXV 32-412		120	110	98	82	68	48		
MXV 32-414		140	130	116	98	78	56		
MXV 32-416		162	138	130	110	88	62		
MXV 32-418		182	168	145	116	100	70		

		Q(m³/h)							
		5	6	7	8	9	10	11	12
MXV-B 40-803	H(m)								
MXV-B 40-804		44	42	40	38	36	36	30	28
MXV-B 40-805/A		54	52	50	48	44	42	38	36
MXV-B 40-806/A		64	62	60	58	56	50	44	38
MXV-B 40-807/A		76	74	72	70	66	60	52	48
MXV-B 40-808/A		88	86	84	80	76	68	60	50
MXV-B 40-810/A		110	108	106	100	94	84	82	70
MXV-B 40-811		118	116	112	108	104	94	84	72
MXV-B 40-813		142	138	134	128	120	110	98	84
MXV-B 40-815		164	160	152	150	140	128	114	96
MXV-B 40-817		184	180	174	170	160	144	118	110
MXV-B 40-819		208	202	196	190	178	164	144	122

		Q(m³/h)							
		10	12	15	17	20	22		
MXV 50-1603	H(m)	50	48	46	40	36	28		
MXV 50-1604		62	60	58	52	44	38		
MXV 50-1605		80	76	72	64	56	44		
MXV 50-1606		94	90	86	78	68	54		
MXV 50-1607		110	106	100	90	80	62		
MXV 50-1608		118	122	116	106	90	70		
MXV 50-1609		144	138	130	118	100	80		
MXV 50-1610		160	152	142	130	118	90		
MXV 50-1611		176	170	158	142	124	100		
MXV 50-1612		192	182	168	154	132	108		
MXV 50-1614		222	216	200	182	158	120		
MXV 50-1616			242	230	210	180	140		

		Q(m³/h)							
		15	20	25	30	35	40		
MXV 65-3202	H(m)	35	34	32	30	26	22		
MXV 65-3203		52	50	46	45	38	34		
MXV 65-3204		70	68	64	58	52	45		
MXV 65-3205		86	82	80	74	65	54		
MXV 65-3206		106	100	95	88	78	68		
MXV 65-3207		120	114	110	102	90	75		
MXV 65-3208		138	134	125	116	104	88		
MXV 65-3209		155	150	142	130	114	98		
MXV 65-3210		174	166	158	145	130	110		
MXV 65-3212		206	200	190	175	155	130		

		Q(m³/h)							
		25	30	35	40	45	50	55	60
MXV 80-4801	H(m)	18	16	15	14	12	11	10	8
MXV 80-4802		36	34	32	30	28	25	22	18
MXV 80-4803		52	50	48	45	40	36	32	26
MXV 80-4804		70	68	62	60	54	50	42	35
MXV 80-4805		88	82	80	75	68	60	52	45
MXV 80-4806		104	100	95	90	80	75	65	54
MXV 80-4807		122	118	112	105	95	85	75	62
MXV 80-4808		140	136	125	118	110	98	85	70

		Q(m³/h)									
		30	40	50	60	70	80				
MXV100-6501 B	H(m)	22	20	18	16	15	14				
MXV100-6501 A		24	24	22	20	18	16				
MXV100-6502 C		42	40	38	36	28	20				
MXV100-6502 B		50	48	46	40	36	30				
MXV100-6502 A		56	54	50	44	42	38				
MXV100-6503 C		74	70	62	58	50	40				
MXV100-6503 B		78	74	70	64	58	50				
MXV100-6503 A		84	80	78	70	64	58				
MXV100-6504 C		100	94	90	82	72	60				
MXV100-6504 B		108	102	96	90	80	68				
MXV100-6504 A		114	110	104	94	90	78				
MXV100-6505 C		128	122	116	108	94	80				
MXV100-6505 B		134	130	122	112	100	88				
MXV100-6505 A		140	134	130	118	110	94				
MXV100-6506 C		158	150	140	130	118	100				
MXV100-6506 B		162	158	150	138	124	108				
MXV100-6506 A		170	162	156	144	132	112				
MXV100-6507 C		182	174	164	154	136	114				
MXV100-6507 B		190	182	172	160	144	124				
MXV100-6507 A		196	190	178	170	152	130				
MXV100-6508 C		210	204	190	176	160	132				
MXV100-6508 B		218	210	198	184	164	144				
MXV100-6508 A		224	216	204	190	172	150				

		Q(m³/h)										
		60	70	80	90	100	110					120
MXV100-9001 B	H(m)	20	18	16	14	12	10	8				
MXV100-9001 A		28	25	23	21	20	18	16				
MXV100-9002 C		42	40	38	32	30	22	18				
MXV100-9002 A		52	50	48	42	40	36	30				
MXV100-9003 C		70	64	60	56	50	42	32				
MXV100-9003 A		82	76	72	64	60	52	46				
MXV100-9004 C		98	90	84	78	70	60	50				
MXV100-9004 A		110	102	94	88	80	72	62				
MXV100-9005 C		124	118	110	100	90	80	63				
MXV100-9005 A		136	126	120	110	100	90	78				
MXV100-9006 C		156	142	132	122	110	98	80				
MXV100-9006 A		162	154	142	132	120	108	96				
MXV100-9007 C		180	170	158	144	130	112	98				

Dimensions of industrial boosters with one pump

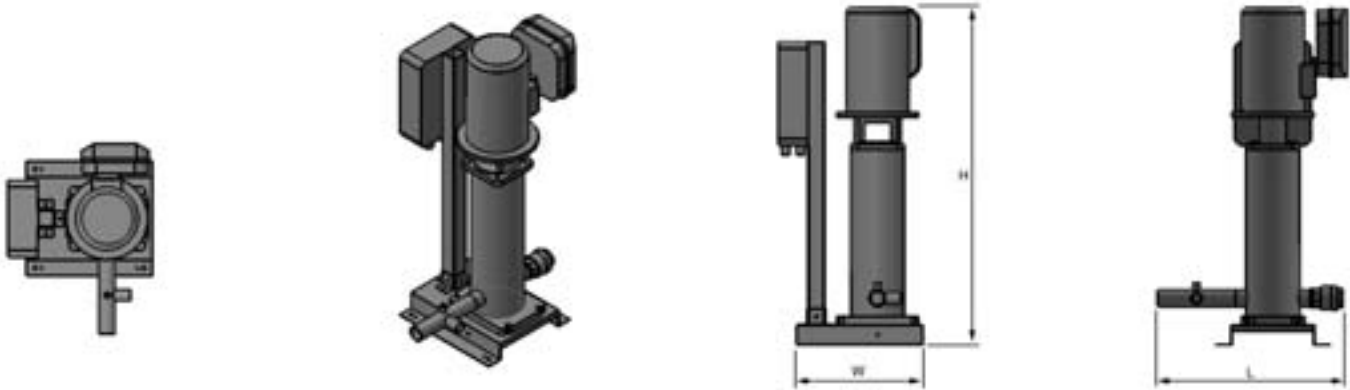

Model	DNs	DNd	H	L	W
1 MXV-B 25/203	1"	1"	850	250	480
1 MXV-B 25/204	1"	1"	850	250	480
1 MXV-B 25/205	1"	1"	850	250	480
1 MXV-B 25/206	1"	1"	850	250	480
1 MXV-B 25/207	1"	1"	850	250	480
1 MXV-B 25/208	1"	1"	850	250	480
1 MXV-B 25/210	1"	1"	850	250	480
1 MXV 25/212	1"	1"	900	250	480
1 MXV 25/214	1"	1"	954	250	480
1 MXV 25/216	1"	1"	1043	250	480
1 MXV 25/218	1"	1"	1091	250	480
1 MXV 25/220	1"	1"	1139	250	480
1 MXV-B 32/403	1 1/4"	1 1/4"	850	260	480
1 MXV-B 32/404	1 1/4"	1 1/4"	850	260	480
1 MXV-B 32/405	1 1/4"	1 1/4"	850	260	480
1 MXV-B 32/406	1 1/4"	1 1/4"	850	260	480
1 MXV-B 32/407	1 1/4"	1 1/4"	850	260	480
1 MXV-B 32/408	1 1/4"	1 1/4"	850	260	480
1 MXV-B 32/410	1 1/4"	1 1/4"	850	260	480
1 MXV 32/412	1 1/4"	1 1/4"	947	260	480
1 MXV 32/414	1 1/4"	1 1/4"	995	260	480
1 MXV 32/416	1 1/4"	1 1/4"	1065	260	480
1 MXV 32/418	1 1/4"	1 1/4"	1102	260	480
1 MXV-B 40/803	1 1/2"	1 1/2"	850	300	480
1 MXV-B 40/804	1 1/2"	1 1/2"	850	300	480
1 MXV-B 40/805	1 1/2"	1 1/2"	850	300	480
1 MXV-B 40/806	1 1/2"	1 1/2"	850	300	480
1 MXV 40/810	1 1/2"	1 1/2"	985	300	480
1 MXV 40/811	1 1/2"	1 1/2"	1015	300	480
1 MXV 40/813	1 1/2"	1 1/2"	1140	300	480
1 MXV 40/815	1 1/2"	1 1/2"	1200	300	480
1 MXV 40/817	1 1/2"	1 1/2"	1260	300	480
1 MXV 40/819	1 1/2"	1 1/2"	1260	300	480

Dimensions of industrial boosters with one pump

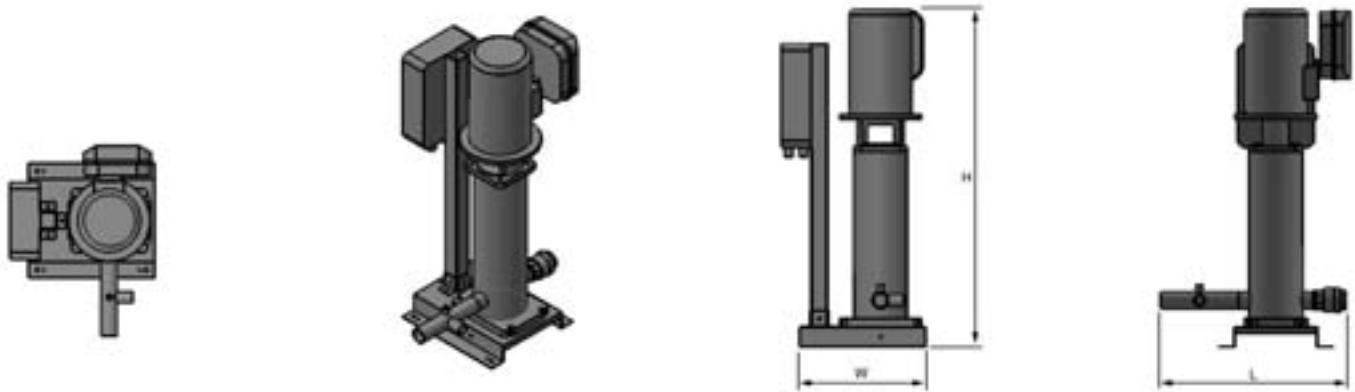

Model	DNs	DNd	H	L	W
1 MXV 50/1603	DN 50	DN 50	708	450	500
1 MXV 50/1604	DN 50	DN 50	743	450	500
1 MXV 50/1605	DN 50	DN 50	777	450	500
1 MXV 50/1606	DN 50	DN 50	812	450	500
1 MXV 50/1607	DN 50	DN 50	846	450	500
1 MXV 50/1608	DN 50	DN 50	881	450	500
1 MXV 50/1609	DN 50	DN 50	915	450	500
1 MXV 50/1610	DN 50	DN 50	950	450	500
1 MXV 50/1611	DN 50	DN 50	984	450	500
1 MXV 50/1612	DN 50	DN 50	1019	450	500
1 MXV 50/1614	DN 50	DN 50	1088	450	500
1 MXV 50/1616	DN 50	DN 50	1157	450	500
1 MXV 65/3202	DN 65	DN 65	720	500	500
1 MXV 65/3203	DN 65	DN 65	766	500	500
1 MXV 65/3204	DN 65	DN 65	812	500	500
1 MXV 65/3205	DN 65	DN 65	858	500	500
1 MXV 65/3206	DN 65	DN 65	904	500	500
1 MXV 65/3207	DN 65	DN 65	950	500	500
1 MXV 65/3208	DN 65	DN 65	996	500	500
1 MXV 65/3209	DN 65	DN 65	1042	500	500
1 MXV 65/3210	DN 65	DN 65	1088	500	500
1 MXV 65/3212	DN 65	DN 65	1268	500	500
1 MXV 80/4803	DN 80	DN 80	820	600	500
1 MXV 80/4804	DN 80	DN 80	881	600	500
1 MXV 80/4805	DN 80	DN 80	943	600	500
1 MXV 80/4806	DN 80	DN 80	1004	600	500
1 MXV 80/4807	DN 80	DN 80	1065	600	500
1 MXV 80/4808	DN 80	DN 80	1127	600	500

Dimensions of industrial boosters with one pump

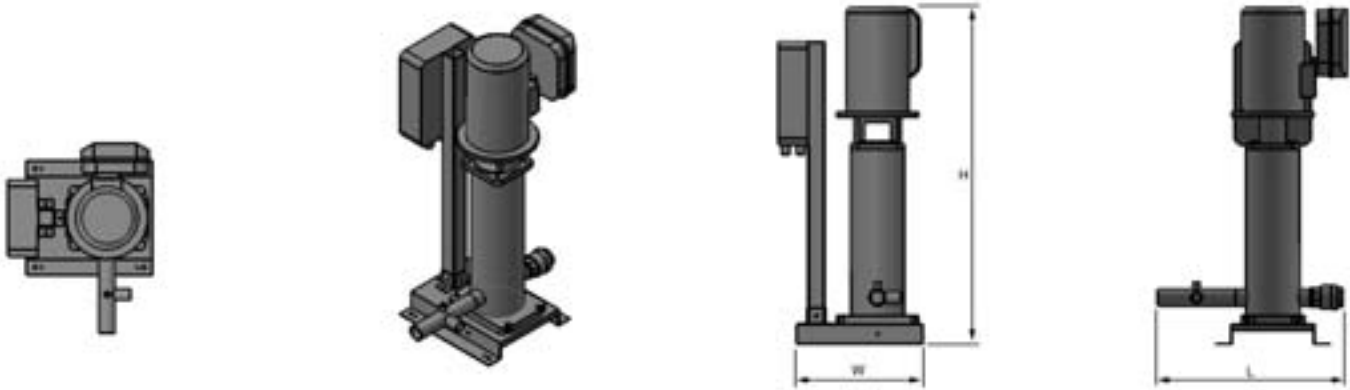

Model	DNs	DNd	H	L	W
1 MXV 100/6501/1	100	100	979	1115	800
1 MXV 100/6501	100	100	1020	1115	800
1 MXV 100/6502/2	100	100	1110	1115	800
1 MXV 100/6502/1	100	100	1319	1115	800
1 MXV 100/6502	100	100	1319	1115	800
1 MXV 100/6503/2	100	100	1409	1115	800
1 MXV 100/6503/1	100	100	1409	1115	800
1 MXV 100/6503	100	100	1409	1115	800
1 MXV 100/6504/2	100	100	1499	1115	800
1 MXV 100/6504/1	100	100	1559	1115	800
1 MXV 100/6504	100	100	1559	1115	800
1 MXV 100/6505/2	100	100	1719	1115	800
1 MXV 100/6505/1	100	100	1719	1115	800
1 MXV 100/6505	100	100	1719	1115	800
1 MXV 100/6506/2	100	100	1809	1115	800
1 MXV 100/6506/1	100	100	1809	1115	800
1 MXV 100/6506	100	100	1809	1115	800
1 MXV 100/6507/2	100	100	1899	1115	800
1 MXV 100/6507/1	100	100	1899	1115	800
1 MXV 100/6507	100	100	1949	1115	800
1 MXV 100/6508/2	100	100	2039	1115	800
1 MXV 100/6508/1	100	100	2039	1115	800
1 MXV 100/6508	100	100	2039	1115	800
1 MXV 100/9001/1	100	100	1020	1115	800
1 MXV 100/9001	100	100	1020	1115	800
1 MXV 100/9002/2	100	100	1319	1115	800
1 MXV 100/9002	100	100	1319	1115	800
1 MXV 100/9003/2	100	100	1409	1115	800
1 MXV 100/9003/2	100	100	1409	1115	800
1 MXV 100/9004/2	100	100	1629	1115	800
1 MXV 100/9004	100	100	1629	1115	800
1 MXV 100/9005/2	100	100	1719	1115	800
1 MXV 100/9005/2	100	100	1719	1115	800
1 MXV 100/9006/2	100	100	1859	1115	800
1 MXV 100/9006	100	100	1859	1115	800
1 MXV 100/9007/2	100	100	1859	1115	800

Dimensions of industrial boosters with two pump

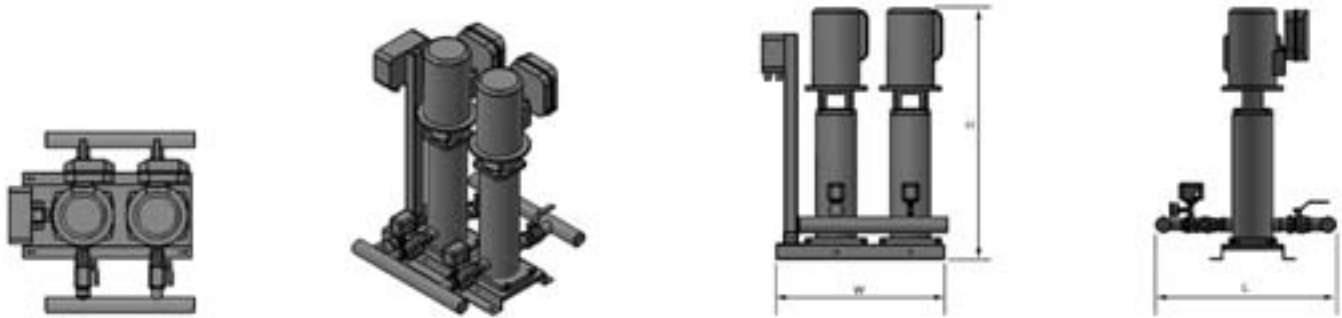

Model	DNs	DNd	H	W	L
2 MXV-B 25/203	1 1/2"	1 1/2"	850	610	600
2 MXV-B 25/204	1 1/2"	1 1/2"	850	610	600
2 MXV-B 25/205	1 1/2"	1 1/2"	850	610	600
2 MXV-B 25/206	1 1/2"	1 1/2"	850	610	600
2 MXV-B 25/207	1 1/2"	1 1/2"	850	610	600
2 MXV-B 25/208	1 1/2"	1 1/2"	850	610	600
2 MXV-B 25/210	1 1/2"	1 1/2"	850	610	600
2 MXV 25/212	1 1/2"	1 1/2"	900	610	600
2 MXV 25/214	1 1/2"	1 1/2"	954	610	600
2 MXV 25/216	1 1/2"	1 1/2"	1043	610	600
2 MXV 25/218	1 1/2"	1 1/2"	1091	610	600
2 MXV 25/220	1 1/2"	1 1/2"	1139	610	600
2 MXV-B 32/403	2"	2"	850	665	600
2 MXV-B 32/404	2"	2"	850	665	600
2 MXV-B 32/405	2"	2"	850	665	600
2 MXV-B 32/406	2"	2"	850	665	600
2 MXV-B 32/407	2"	2"	850	665	600
2 MXV-B 32/408	2"	2"	850	665	600
2 MXV-B 32/410	2"	2"	850	665	600
2 MXV 32/412	2"	2"	947	665	600
2 MXV 32/414	2"	2"	995	665	600
2 MXV 32/416	2"	2"	1065	665	600
2 MXV 32/418	2"	2"	1102	665	600
2 MXV-B 40/803	2"	2"	850	750	600
2 MXV-B 40/804	2"	2"	850	750	600
2 MXV-B 40/805	2"	2"	850	750	600
2 MXV-B 40/806	2"	2"	850	750	600
2 MXV 40/807	2"	2"	850	750	600
2 MXV 40/808	2"	2"	904	750	600
2 MXV 40/810	2"	2"	985	750	600
2 MXV 40/811	2"	2"	1015	750	600
2 MXV 40/813	2"	2"	1140	750	600
2 MXV 40/815	2"	2"	1200	750	600
2 MXV 40/817	2"	2"	1260	750	600
2 MXV 40/819	2"	2"	1220	750	600

Dimensions of industrial boosters with two pump

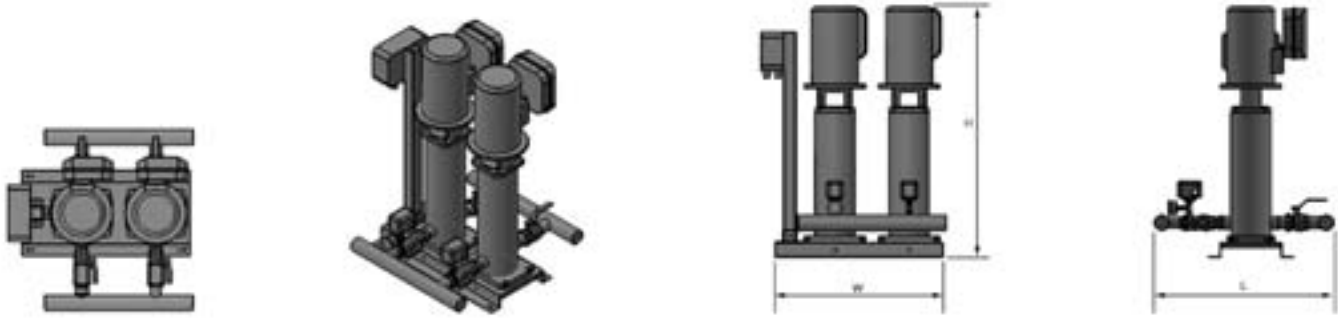

Model	DNs	DNd	H	W	L
2 MXV 50/1603	2 1/2"	2 1/2"	1050	935	800
2 MXV 50/1604	2 1/2"	2 1/2"	1050	935	800
2 MXV 50/1605	2 1/2"	2 1/2"	1050	935	800
2 MXV 50/1606	2 1/2"	2 1/2"	1050	935	800
2 MXV 50/1607	2 1/2"	2 1/2"	1050	935	800
2 MXV 50/1608	2 1/2"	2 1/2"	1050	935	800
2 MXV 50/1609	2 1/2"	2 1/2"	1230	935	800
2 MXV 50/1610	2 1/2"	2 1/2"	1265	935	800
2 MXV 50/1611	2 1/2"	2 1/2"	1300	935	800
2 MXV 50/1612	2 1/2"	2 1/2"	1334	935	800
2 MXV 50/1614	2 1/2"	2 1/2"	1403	935	800
2 MXV 50/1616	2 1/2"	2 1/2"	1472	935	800
2 MXV 65/3202	DN 100	DN 100	1000	1070	800
2 MXV 65/3203	DN 100	DN 100	1000	1070	800
2 MXV 65/3204	DN 100	DN 100	1000	1070	800
2 MXV 65/3205	DN 100	DN 100	1173	1070	800
2 MXV 65/3206	DN 100	DN 100	1219	1070	800
2 MXV 65/3207	DN 100	DN 100	1265	1070	800
2 MXV 65/3208	DN 100	DN 100	1311	1070	800
2 MXV 65/3209	DN 100	DN 100	1357	1070	800
2 MXV 65/3210	DN 100	DN 100	1403	1070	800
2 MXV 65/3212	DN 100	DN 100	1619	1070	800
2 MXV 80/4801	DN 125	DN 125	1000	1135	800
2 MXV 80/4802	DN 125	DN 125	1000	1135	800
2 MXV 80/4803	DN 125	DN 125	1000	1135	800
2 MXV 80/4804	DN 125	DN 125	1196	1135	800
2 MXV 80/4805	DN 125	DN 125	1258	1135	800
2 MXV 80/4806	DN 125	DN 125	1319	1135	800
2 MXV 80/4807	DN 125	DN 125	1380	1135	800
2 MXV 80/4808	DN 125	DN 125	1566	1135	800

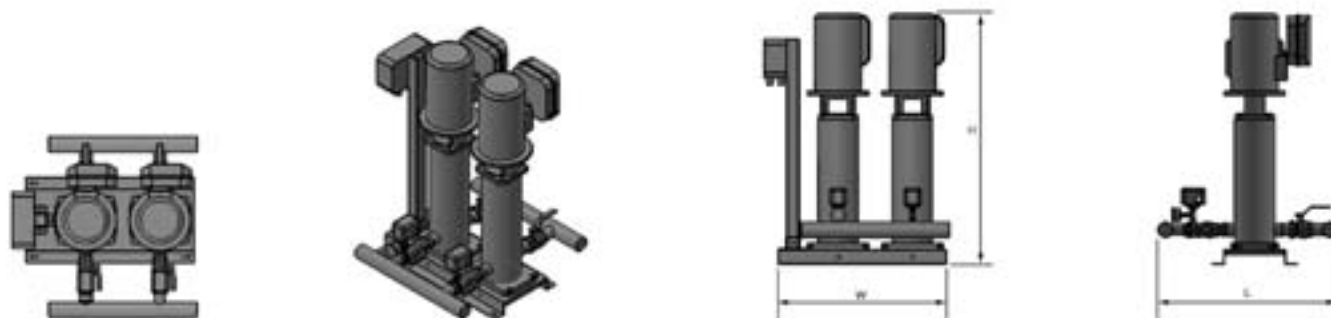
Dimensions of industrial boosters with two pump

Model	DNs	DNd	H	W	L
2 MXV 100/6501/1	150	150	979	1165	800
2 MXV 100/6501	150	150	1020	1165	800
2 MXV 100/6502/2	150	150	1110	1165	800
2 MXV 100/6502/1	150	150	1319	1165	900
2 MXV 100/6502	150	150	1319	1165	900
2 MXV 100/6503/2	150	150	1409	1165	900
2 MXV 100/6503/1	150	150	1409	1165	900
2 MXV 100/6503	150	150	1409	1165	900
2 MXV 100/6504/2	150	150	1499	1165	900
2 MXV 100/6504/1	150	150	1559	1165	900
2 MXV 100/6504	150	150	1559	1165	900
2 MXV 100/6505/2	150	150	1719	1165	1000
2 MXV 100/6505/1	150	150	1719	1165	1000
2 MXV 100/6505	150	150	1719	1165	1000
2 MXV 100/6506/2	150	150	1809	1165	1000
2 MXV 100/6506/1	150	150	1809	1165	1000
2 MXV 100/6506	150	150	1809	1165	1000
2 MXV 100/6507/2	150	150	1899	1165	1000
2 MXV 100/6507/1	150	150	1899	1165	1000
2 MXV 100/6507	150	150	1949	1165	1100
2 MXV 100/6508/2	150	150	2039	1165	1100
2 MXV 100/6508/1	150	150	2039	1165	1100
2 MXV 100/6508	150	150	2039	1165	1100
2 MXV 100/9001/1	150	150	1020	1165	800
2 MXV 100/9001	150	150	1020	1165	800
2 MXV 100/9002/2	150	150	1319	1165	900
2 MXV 100/9002	150	150	1319	1165	900
2 MXV 100/9003/2	150	150	1409	1165	900
2 MXV 100/9003/2	150	150	1409	1165	900
2 MXV 100/9004/2	150	150	1629	1165	1000
2 MXV 100/9004	150	150	1629	1165	1000
2 MXV 100/9005/2	150	150	1719	1165	1000
2 MXV 100/9005/2	150	150	1719	1165	1000
2 MXV 100/9006/2	150	150	1859	1165	1100
2 MXV 100/9006	150	150	1859	1165	1100
2 MXV 100/9007/2	150	150	1859	1165	1100

Dimensions of industrial boosters with three pump

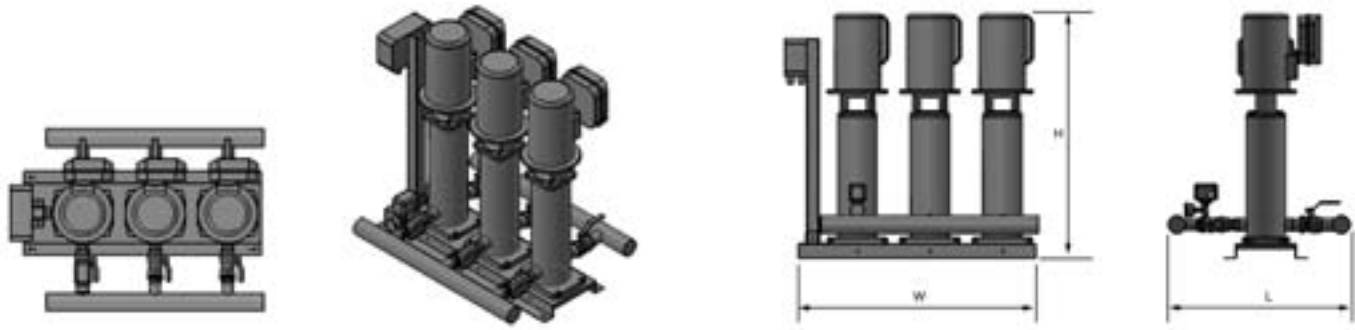

Model	DNs	DNd	H	W	L
3 MXV-B 25/204	2"	2"	1000	655	900
3 MXV-B 25/205	2"	2"	1000	655	900
3 MXV-B 25/206	2"	2"	1000	655	900
3 MXV-B 25/207	2"	2"	1000	655	900
3 MXV-B 25/208	2"	2"	1000	655	900
3 MXV-B 25/210	2"	2"	1000	655	900
3 MXV 25/212	2"	2"	1000	655	900
3 MXV 25/214	2"	2"	1000	655	900
3 MXV 25/216	2"	2"	1043	655	900
3 MXV 25/218	2"	2"	1139	655	900
3 MXV-B 32/403	2"	2"	850	665	900
3 MXV-B 32/404	2"	2"	850	665	900
3 MXV-B 32/405	2"	2"	850	665	900
3 MXV-B 32/406	2"	2"	850	665	900
3 MXV-B 32/407	2"	2"	850	665	900
3 MXV-B 32/408	2"	2"	850	665	900
3 MXV-B 32/410	2"	2"	850	665	900
3 MXV 32/412	2"	2"	947	665	900
3 MXV 32/414	2"	2"	995	665	900
3 MXV 32/416	2"	2"	1065	665	900
3 MXV 32/418	2"	2"	1102	665	900
3 MXV-B 40/803	2 1/2"	2 1/2"	850	795	900
3 MXV-B 40/804	2 1/2"	2 1/2"	850	795	900
3 MXV-B 40/805	2 1/2"	2 1/2"	850	795	900
3 MXV-B 40/806	2 1/2"	2 1/2"	850	795	900
3 MXV 40/807	2 1/2"	2 1/2"	850	795	900
3 MXV 40/808	2 1/2"	2 1/2"	904	795	900
3 MXV 40/810	2 1/2"	2 1/2"	985	795	900
3 MXV 40/811	2 1/2"	2 1/2"	1015	795	900
3 MXV 40/813	2 1/2"	2 1/2"	1140	795	900
3 MXV 40/815	2 1/2"	2 1/2"	1200	795	900
3 MXV 40/817	2 1/2"	2 1/2"	1260	795	900
3 MXV 40/819	2 1/2"	2 1/2"	1320	795	900

Dimensions of industrial boosters with three pump

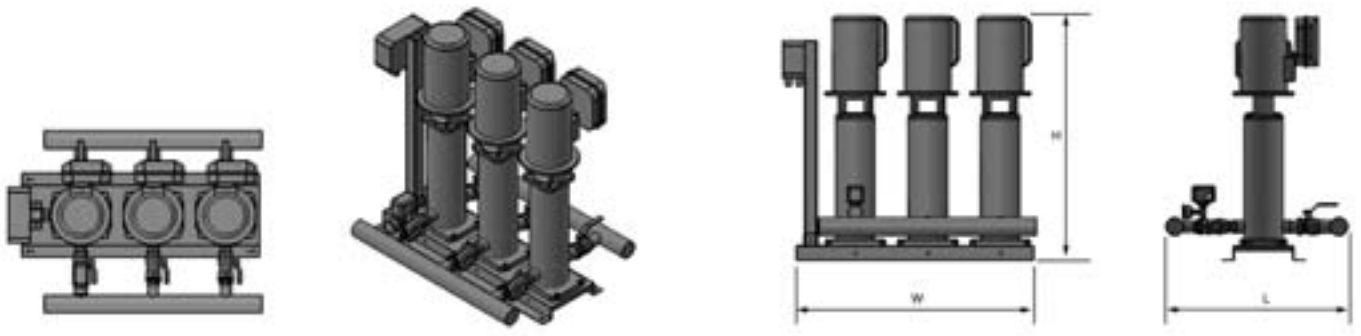

Model	DNs	DNd	H	W	L
3 MXV 50/1603	DN 100	DN 100	1050	1030	1200
3 MXV 50/1604	DN 100	DN 100	1050	1030	1200
3 MXV 50/1605	DN 100	DN 100	1050	1030	1200
3 MXV 50/1606	DN 100	DN 100	1050	1030	1200
3 MXV 50/1607	DN 100	DN 100	1050	1030	1200
3 MXV 50/1608	DN 100	DN 100	1050	1030	1200
3 MXV 50/1609	DN 100	DN 100	1230	1030	1200
3 MXV 50/1610	DN 100	DN 100	1265	1030	1200
3 MXV 50/1611	DN 100	DN 100	1300	1030	1200
3 MXV 50/1612	DN 100	DN 100	1334	1030	1200
3 MXV 50/1614	DN 100	DN 100	1403	1030	1200
3 MXV 50/1616	DN 100	DN 100	1472	1030	1200
3 MXV 65/3202	DN 125	DN 125	1000	1100	1200
3 MXV 65/3203	DN 125	DN 125	1000	1100	1200
3 MXV 65/3204	DN 125	DN 125	1000	1100	1200
3 MXV 65/3205	DN 125	DN 125	1173	1100	1200
3 MXV 65/3206	DN 125	DN 125	1219	1100	1200
3 MXV 65/3207	DN 125	DN 125	1265	1100	1200
3 MXV 65/3208	DN 125	DN 125	1311	1100	1200
3 MXV 65/3209	DN 125	DN 125	1357	1100	1200
3 MXV 65/3210	DN 125	DN 125	1403	1100	1200
3 MXV 65/3212	DN 125	DN 125	1619	1100	1200
3 MXV 80/4801	DN 150	DN 150	1000	1180	1200
3 MXV 80/4802	DN 150	DN 150	1000	1180	1200
3 MXV 80/4803	DN 150	DN 150	1000	1180	1200
3 MXV 80/4804	DN 150	DN 150	1196	1180	1200
3 MXV 80/4805	DN 150	DN 150	1258	1180	1200
3 MXV 80/4806	DN 150	DN 150	1319	1180	1200
3 MXV 80/4807	DN 150	DN 150	1380	1180	1200
3 MXV 80/4808	DN 150	DN 150	1566	1180	1200

Dimensions of industrial boosters with three pump

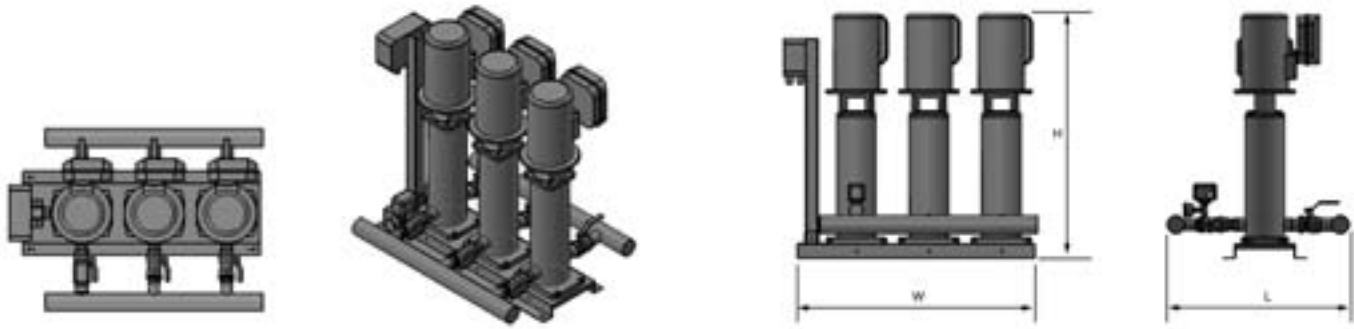

Model	DNs	DNd	H	W	L
3 MXV 100/6501/1	200	200	989	1215	1200
3 MXV 100/6501	200	200	1030	1215	1200
3 MXV 100/6502/2	200	200	1120	1215	1200
3 MXV 100/6502/1	200	200	1329	1215	1350
3 MXV 100/6502	200	200	1329	1215	1350
3 MXV 100/6503/2	200	200	1419	1215	1350
3 MXV 100/6503/1	200	200	1419	1215	1350
3 MXV 100/6503	200	200	1419	1215	1350
3 MXV 100/6504/2	200	200	1519	1215	1350
3 MXV 100/6504/1	200	200	1519	1215	1350
3 MXV 100/6504	200	200	1519	1215	1350
3 MXV 100/6505/2	200	200	1739	1215	1500
3 MXV 100/6505/1	200	200	1739	1215	1500
3 MXV 100/6505	200	200	1739	1215	1500
3 MXV 100/6506/2	200	200	1829	1215	1500
3 MXV 100/6506/1	200	200	1829	1215	1500
3 MXV 100/6506	200	200	1829	1215	1500
3 MXV 100/6507/2	200	200	1919	1215	1500
3 MXV 100/6507/1	200	200	1919	1215	1500
3 MXV 100/6507	200	200	1969	1215	1650
3 MXV 100/6508/2	200	200	2059	1215	1650
3 MXV 100/6508/1	200	200	2059	1215	1650
3 MXV 100/6508	200	200	2059	1215	1650
3 MXV 100/9001/1	200	200	1020	1215	1200
3 MXV 100/9001	200	200	1020	1215	1200
3 MXV 100/9002/2	200	200	1319	1215	1350
3 MXV 100/9002	200	200	1319	1215	1350
3 MXV 100/9003/2	200	200	1409	1215	1350
3 MXV 100/9003/2	200	200	1409	1215	1350
3 MXV 100/9004/2	200	200	1629	1215	1500
3 MXV 100/9004	200	200	1629	1215	1500
3 MXV 100/9005/2	200	200	1719	1215	1500
3 MXV 100/9005/2	200	200	1719	1215	1500
3 MXV 100/9006/2	200	200	1859	1215	1650
3 MXV 100/9006	200	200	1859	1215	1650
3 MXV 100/9007/2	200	200	1859	1215	1650

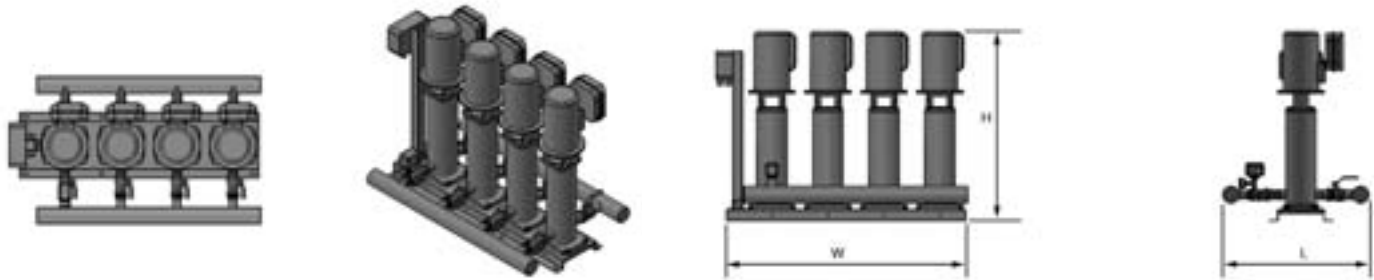
Dimensions of industrial boosters with four pump

Model	DNs	DNd	H	W	L
4 MXV-B 25/203	2"	2"	850	680	1200
4 MXV-B 25/204	2"	2"	850	680	1200
4 MXV-B 25/205	2"	2"	850	680	1200
4 MXV-B 25/206	2"	2"	850	680	1200
4 MXV-B 25/207	2"	2"	850	680	1200
4 MXV-B 25/208	2"	2"	850	680	1200
4 MXV-B 25/210	2"	2"	850	680	1200
4 MXV 25/212	2"	2"	900	680	1200
4 MXV 25/214	2"	2"	954	680	1200
4 MXV 25/216	2"	2"	1043	680	1200
4 MXV 25/218	2"	2"	1091	680	1200
4 MXV 25/220	2"	2"	1139	680	1200
4 MXV-B 32/403	2 1/2"	2 1/2"	1000	720	1200
4 MXV-B 32/404	2 1/2"	2 1/2"	1000	720	1200
4 MXV-B 32/405	2 1/2"	2 1/2"	1000	720	1200
4 MXV-B 32/406	2 1/2"	2 1/2"	1000	720	1200
4 MXV-B 32/407	2 1/2"	2 1/2"	1000	720	1200
4 MXV-B 32/408	2 1/2"	2 1/2"	1000	720	1200
4 MXV-B 32/410	2 1/2"	2 1/2"	1000	720	1200
4 MXV 32/412	2 1/2"	2 1/2"	1000	720	1200
4 MXV 32/414	2 1/2"	2 1/2"	1000	720	1200
4 MXV 32/416	2 1/2"	2 1/2"	1065	720	1200
4 MXV 32/418	2 1/2"	2 1/2"	1102	720	1200
4 MXV-B 40/803	DN 80	DN 80	1000	865	1200
4 MXV-B 40/804	DN 80	DN 80	1000	865	1200
4 MXV-B 40/805	DN 80	DN 80	1000	865	1200
4 MXV-B 40/806	DN 80	DN 80	1000	865	1200
4 MXV 40/807	DN 80	DN 80	1000	865	1200
4 MXV 40/808	DN 80	DN 80	1000	865	1200
4 MXV 40/810	DN 80	DN 80	1000	865	1200
4 MXV 40/811	DN 80	DN 80	1015	865	1200
4 MXV 40/813	DN 80	DN 80	1140	865	1200
4 MXV 40/815	DN 80	DN 80	1200	865	1200
4 MXV 40/817	DN 80	DN 80	1260	865	1200
4 MXV 40/819	DN 80	DN 80	1320	865	1200

Dimensions of industrial boosters with four pump

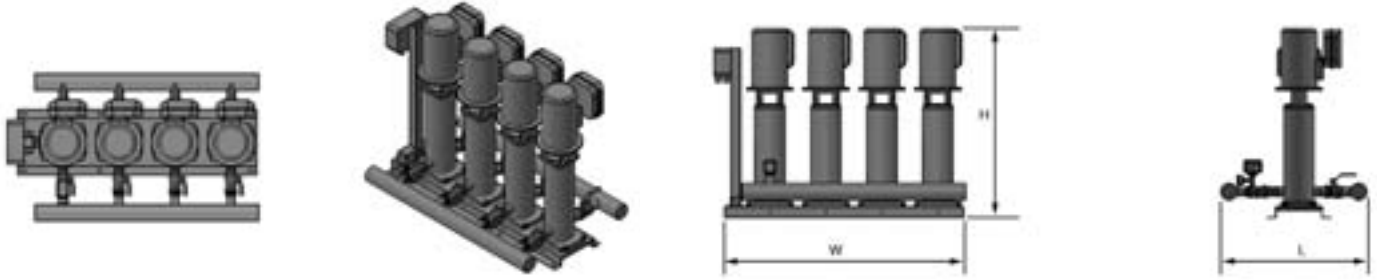

Model	DNs	DNd	H	W	L
4 MXV 50/1603	DN 100	DN 100	1050	765	1600
4 MXV 50/1604	DN 100	DN 100	1050	765	1600
4 MXV 50/1605	DN 100	DN 100	1050	765	1600
4 MXV 50/1606	DN 100	DN 100	1050	765	1600
4 MXV 50/1607	DN 100	DN 100	1050	765	1600
4 MXV 50/1608	DN 100	DN 100	1050	765	1600
4 MXV 50/1609	DN 100	DN 100	1230	765	1600
4 MXV 50/1610	DN 100	DN 100	1265	765	1600
4 MXV 50/1611	DN 100	DN 100	1300	765	1600
4 MXV 50/1612	DN 100	DN 100	1334	765	1600
4 MXV 50/1614	DN 100	DN 100	1403	765	1600
4 MXV 50/1616	DN 100	DN 100	1472	765	1600
4 MXV 65/3202	DN 150	DN 150	1000	1140	1600
4 MXV 65/3203	DN 150	DN 150	1000	1140	1600
4 MXV 65/3204	DN 150	DN 150	1000	1140	1600
4 MXV 65/3205	DN 150	DN 150	1173	1140	1600
4 MXV 65/3206	DN 150	DN 150	1219	1140	1600
4 MXV 65/3207	DN 150	DN 150	1265	1140	1600
4 MXV 65/3208	DN 150	DN 150	1311	1140	1600
4 MXV 65/3210	DN 150	DN 150	1357	1140	1600
4 MXV 65/3212	DN 150	DN 150	1619	1140	1600
4 MXV 80/4801	DN 150	DN 150	1000	1180	1600
4 MXV 80/4802	DN 150	DN 150	1000	1180	1600
4 MXV 80/4803	DN 150	DN 150	1000	1180	1600
4 MXV 80/4804	DN 150	DN 150	1196	1180	1600
4 MXV 80/4805	DN 150	DN 150	1258	1180	1600
4 MXV 80/4806	DN 150	DN 150	1319	1180	1600
4 MXV 80/4807	DN 150	DN 150	1380	1180	1600
4 MXV 80/4808	DN 150	DN 150	1566	1180	1600

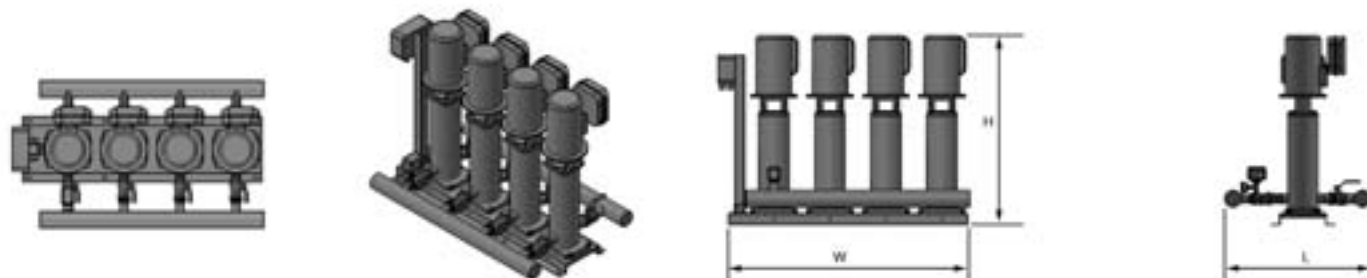
Dimensions of industrial boosters with four pump

Model	DNs	DNd	H	W	L
4 MXV 100/6501/1	250	250	1019	1265	1600
4 MXV 100/6501	250	250	1060	1265	1600
4 MXV 100/6502/2	250	250	1150	1265	1600
4 MXV 100/6502/1	250	250	1359	1265	1800
4 MXV 100/6502	250	250	1359	1265	1800
4 MXV 100/6503/2	250	250	1469	1265	1800
4 MXV 100/6503/1	250	250	1469	1265	1800
4 MXV 100/6503	250	250	1469	1265	1800
4 MXV 100/6504/2	250	250	1539	1265	1800
4 MXV 100/6504/1	250	250	1539	1265	1800
4 MXV 100/6504	250	250	1539	1265	1800
4 MXV 100/6505/2	250	250	1759	1265	2000
4 MXV 100/6505/1	250	250	1759	1265	2000
4 MXV 100/6505	250	250	1759	1265	2000
4 MXV 100/6506/2	250	250	1849	1265	2000
4 MXV 100/6506/1	250	250	1849	1265	2000
4 MXV 100/6506	250	250	1849	1265	2000
4 MXV 100/6507/2	250	250	1939	1265	2000
4 MXV 100/6507/1	250	250	1939	1265	2000
4 MXV 100/6507	250	250	1989	1265	2200
4 MXV 100/6508/2	250	250	2079	1265	2200
4 MXV 100/6508/1	250	250	2079	1265	2200
4 MXV 100/6508	250	250	2079	1265	2200
4 MXV 100/9001/1	250	250	1060	1265	1600
4 MXV 100/9001	250	250	1060	1265	1600
4 MXV 100/9002/2	250	250	1359	1265	1800
4 MXV 100/9002	250	250	1359	1265	1800
4 MXV 100/9003/2	250	250	1449	1265	1800
4 MXV 100/9003/1	250	250	1509	1265	1800
4 MXV 100/9004/2	250	250	1669	1265	2000
4 MXV 100/9004	250	250	1669	1265	2000
4 MXV 100/9005/2	250	250	1759	1265	2000
4 MXV 100/9005/1	250	250	1759	1265	2000
4 MXV 100/9006/2	250	250	1899	1265	2200
4 MXV 100/9006	250	250	1899	1265	2200
4 MXV 100/9007/2	250	250	1989	1265	2200

Dimensions of industrial boosters with five pump

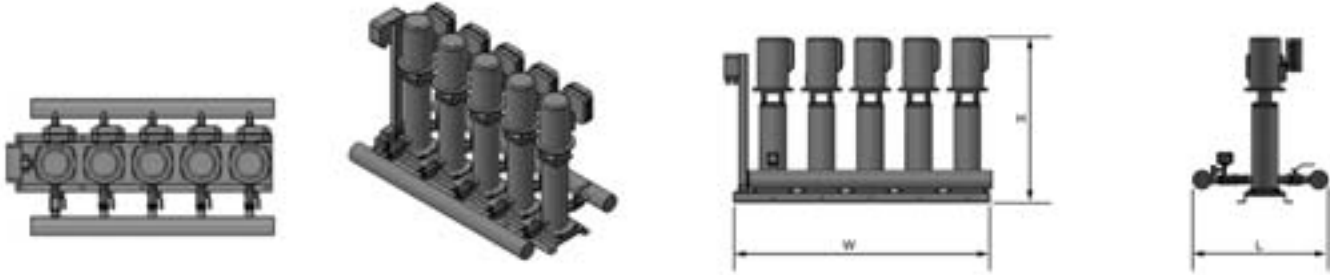

Model	DNs	DNd	H	W	L
5 MXV-B 25/203	2"	2"	610	680	1500
5 MXV-B 25/204	2"	2"	610	680	1500
5 MXV-B 25/205	2"	2"	643	680	1500
5 MXV-B 25/206	2"	2"	667	680	1500
5 MXV-B 25/207	2"	2"	691	680	1500
5 MXV-B 25/208	2"	2"	715	680	1500
5 MXV-B 25/210	2"	2"	763	680	1500
5 MXV 25/212	2"	2"	900	680	1500
5 MXV 25/214	2"	2"	954	680	1500
5 MXV 25/216	2"	2"	1043	680	1500
5 MXV 25/218	2"	2"	1091	680	1500
5 MXV 25/220	2"	2"	1139	680	1500
5 MXV-B 32/403	2 1/2"	2 1/2"	610	720	1500
5 MXV-B 32/404	2 1/2"	2 1/2"	610	720	1500
5 MXV-B 32/405	2 1/2"	2 1/2"	643	720	1500
5 MXV-B 32/406	2 1/2"	2 1/2"	667	720	1500
5 MXV-B 32/407	2 1/2"	2 1/2"	691	720	1500
5 MXV-B 32/408	2 1/2"	2 1/2"	715	720	1500
5 MXV-B 32/410	2 1/2"	2 1/2"	763	720	1500
5 MXV 32/412	2 1/2"	2 1/2"	900	720	1500
5 MXV 32/414	2 1/2"	2 1/2"	954	720	1500
5 MXV 32/416	2 1/2"	2 1/2"	1065	720	1500
5 MXV 32/418	2 1/2"	2 1/2"	1102	720	1500
5 MXV-B 40/803	DN 100	DN 100	643	895	1500
5 MXV-B 40/804	DN 100	DN 100	643	895	1500
5 MXV-B 40/805	DN 100	DN 100	673	895	1500
5 MXV-B 40/806	DN 100	DN 100	703	895	1500
5 MXV 40/807	DN 100	DN 100	878	895	1500
5 MXV 40/808	DN 100	DN 100	904	895	1500
5 MXV 40/810	DN 100	DN 100	985	895	1500
5 MXV 40/811	DN 100	DN 100	1015	895	1500
5 MXV 40/813	DN 100	DN 100	1140	895	1500
5 MXV 40/815	DN 100	DN 100	1200	895	1500
5 MXV 40/817	DN 100	DN 100	1260	895	1500
5 MXV 40/819	DN 100	DN 100	1320	895	1500

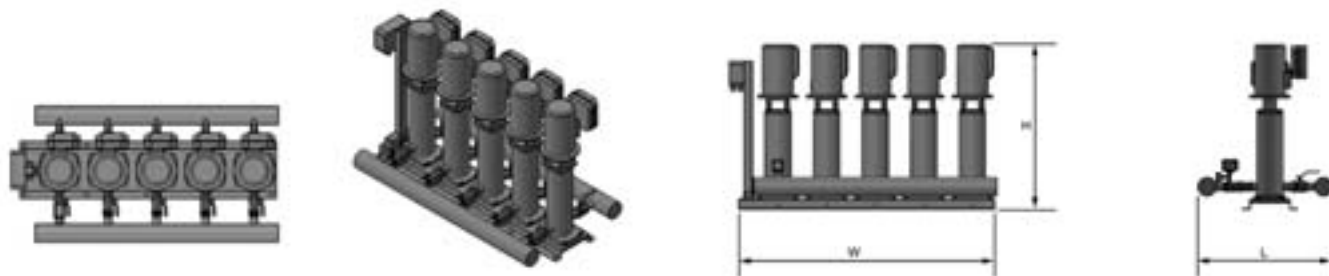
Dimensions of industrial boosters with five pump

Model	DNs	DNd	H	W	L
5 MXV 50/1603	DN 125	DN 125	1050	1065	2000
5 MXV 50/1604	DN 125	DN 125	1050	1065	2000
5 MXV 50/1605	DN 125	DN 125	1050	1065	2000
5 MXV 50/1606	DN 125	DN 125	1050	1065	2000
5 MXV 50/1607	DN 125	DN 125	1050	1065	2000
5 MXV 50/1608	DN 125	DN 125	1050	1065	2000
5 MXV 50/1609	DN 125	DN 125	1230	1065	2000
5 MXV 50/1610	DN 125	DN 125	1265	1065	2000
5 MXV 50/1611	DN 125	DN 125	1300	1065	2000
5 MXV 50/1612	DN 125	DN 125	1334	1065	2000
5 MXV 50/1614	DN 125	DN 125	1403	1065	2000
5 MXV 50/1616	DN 125	DN 125	1472	1065	2000
5 MXV 65/3202	DN 150	DN 150	841	1140	2000
5 MXV 65/3203	DN 150	DN 150	947	1140	2000
5 MXV 65/3204	DN 150	DN 150	993	1140	2000
5 MXV 65/3205	DN 150	DN 150	1173	1140	2000
5 MXV 65/3206	DN 150	DN 150	1219	1140	2000
5 MXV 65/3207	DN 150	DN 150	1265	1140	2000
5 MXV 65/3208	DN 150	DN 150	1311	1140	2000
5 MXV 65/3209	DN 150	DN 150	1357	1140	2000
5 MXV 65/3210	DN 150	DN 150	1403	1140	2000
5 MXV 65/3212	DN 150	DN 150	1619	1140	2000
5 MXV 80/4801	DN 200	DN 200	845	1250	2000
5 MXV 80/4802	DN 200	DN 200	940	1250	2000
5 MXV 80/4803	DN 200	DN 200	1001	1250	2000
5 MXV 80/4804	DN 200	DN 200	1196	1250	2000
5 MXV 80/4805	DN 200	DN 200	1258	1250	2000
5 MXV 80/4806	DN 200	DN 200	1319	1250	2000
5 MXV 80/4807	DN 200	DN 200	1380	1250	2000
5 MXV 80/4808	DN 200	DN 200	1566	1250	2000

Dimensions of industrial boosters with five pump

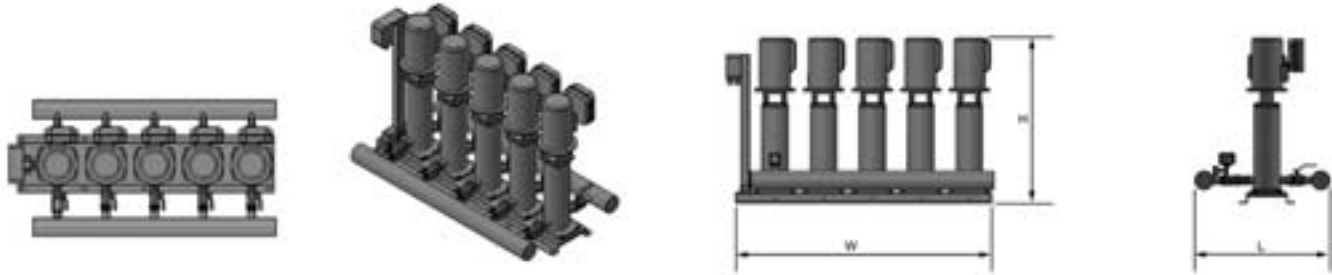

Model	DNs	DNd	H	W	L
5 MXV 100/6501/1	300	300	1019	1315	2000
5 MXV 100/6501	300	300	1060	1315	2000
5 MXV 100/6502/2	300	300	1150	1315	2000
5 MXV 100/6502/1	300	300	1359	1315	2250
5 MXV 100/6502	300	300	1359	1315	2250
5 MXV 100/6503/2	300	300	1469	1315	2250
5 MXV 100/6503/1	300	300	1469	1315	2250
5 MXV 100/6503	300	300	1469	1315	2250
5 MXV 100/6504/2	300	300	1539	1315	2250
5 MXV 100/6504/1	300	300	1539	1315	2250
5 MXV 100/6504	300	300	1539	1315	2250
5 MXV 100/6505/2	300	300	1759	1315	2500
5 MXV 100/6505/1	300	300	1759	1315	2500
5 MXV 100/6505	300	300	1759	1315	2500
5 MXV 100/6506/2	300	300	1849	1315	2500
5 MXV 100/6506/1	300	300	1849	1315	2500
5 MXV 100/6506	300	300	1849	1315	2500
5 MXV 100/6507/2	300	300	1939	1315	2500
5 MXV 100/6507/1	300	300	1939	1315	2500
5 MXV 100/6507	300	300	1989	1315	2750
5 MXV 100/6508/2	300	300	2079	1315	2750
5 MXV 100/6508/1	300	300	2079	1315	2750
5 MXV 100/6508	300	300	2079	1315	2750
5 MXV 100/9001/1	300	300	1020	1315	2000
5 MXV 100/9001	300	300	1020	1315	2000
5 MXV 100/9002/2	300	300	1319	1315	2250
5 MXV 100/9002	300	300	1319	1315	2250
5 MXV 100/9003/2	300	300	1409	1315	2250
5 MXV 100/9003/2	300	300	1409	1315	2250
5 MXV 100/9004/2	300	300	1629	1315	2500
5 MXV 100/9004	300	300	1629	1315	2500
5 MXV 100/9005/2	300	300	1719	1315	2500
5 MXV 100/9005/2	300	300	1719	1315	2500
5 MXV 100/9006/2	300	300	1859	1315	2750
5 MXV 100/9006	300	300	1859	1315	2750
5 MXV 100/9007/2	300	300	1859	1315	2750

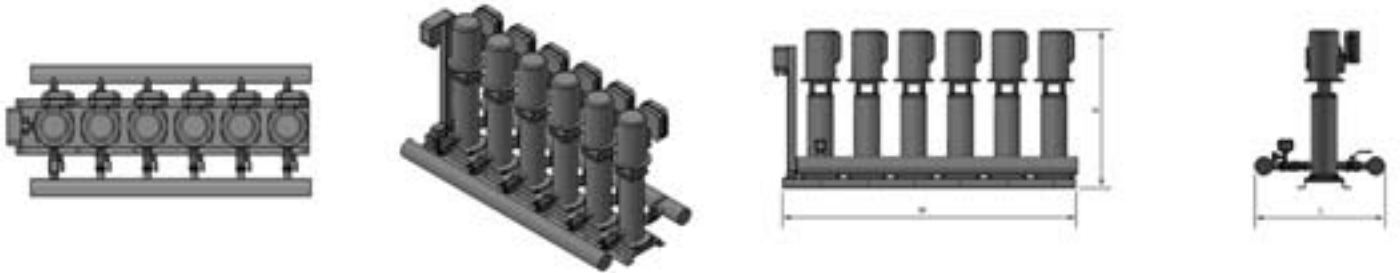
Dimensions of industrial boosters with six pump

Model	DNs	DNd	H	W	L
6 MXV-B 25/203	2"	2"	610	680	1800
6 MXV-B 25/204	2"	2"	610	680	1800
6 MXV-B 25/205	2"	2"	643	680	1800
6 MXV-B 25/206	2"	2"	667	680	1800
6 MXV-B 25/207	2"	2"	691	680	1800
6 MXV-B 25/208	2"	2"	715	680	1800
6 MXV-B 25/210	2"	2"	763	680	1800
6 MXV 25/212	2"	2"	900	680	1800
6 MXV 25/214	2"	2"	954	680	1800
6 MXV 25/216	2"	2"	1043	680	1800
6 MXV 25/218	2"	2"	1091	680	1800
6 MXV 25/220	2"	2"	1139	680	1800
6 MXV-B 32/403	2 1/2"	2 1/2"	610	720	1800
6 MXV-B 32/404	2 1/2"	2 1/2"	610	720	1800
6 MXV-B 32/405	2 1/2"	2 1/2"	643	720	1800
6 MXV-B 32/406	2 1/2"	2 1/2"	667	720	1800
6 MXV-B 32/407	2 1/2"	2 1/2"	691	720	1800
6 MXV-B 32/408	2 1/2"	2 1/2"	715	720	1800
6 MXV-B 32/410	2 1/2"	2 1/2"	763	720	1800
6 MXV 32/412	2 1/2"	2 1/2"	900	720	1800
6 MXV 32/414	2 1/2"	2 1/2"	954	720	1800
6 MXV 32/416	2 1/2"	2 1/2"	1065	720	1800
6 MXV 32/418	2 1/2"	2 1/2"	1102	720	1800
6 MXV-B 40/803	DN 100	DN 100	643	895	1800
6 MXV-B 40/804	DN 100	DN 100	643	895	1800
6 MXV-B 40/805	DN 100	DN 100	673	895	1800
6 MXV-B 40/806	DN 100	DN 100	703	895	1800
6 MXV 40/807	DN 100	DN 100	878	895	1800
6 MXV 40/808	DN 100	DN 100	904	895	1800
6 MXV 40/810	DN 100	DN 100	985	895	1800
6 MXV 40/811	DN 100	DN 100	1015	895	1800
6 MXV 40/813	DN 100	DN 100	1140	895	1800
6 MXV 40/815	DN 100	DN 100	1200	895	1800
6 MXV 40/817	DN 100	DN 100	1260	895	1800
6 MXV 40/819	DN 100	DN 100	1320	895	1800

Dimensions of industrial boosters with six pump

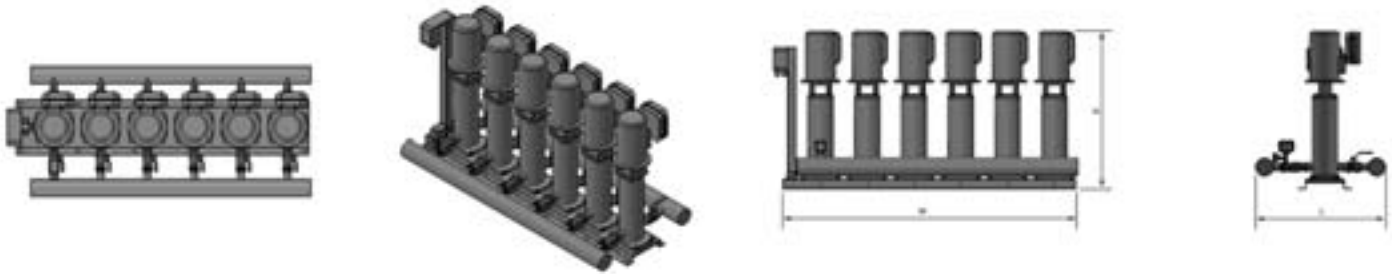

Model	DNs	DNd	H	W	L
6 MXV 50/1603	DN 125	DN 125	1050	1065	2400
6 MXV 50/1604	DN 125	DN 125	1050	1065	2400
6 MXV 50/1605	DN 125	DN 125	1050	1065	2400
6 MXV 50/1606	DN 125	DN 125	1050	1065	2400
6 MXV 50/1607	DN 125	DN 125	1050	1065	2400
6 MXV 50/1608	DN 125	DN 125	1050	1065	2400
6 MXV 50/1609	DN 125	DN 125	1230	1065	2400
6 MXV 50/1610	DN 125	DN 125	1265	1065	2400
6 MXV 50/1611	DN 125	DN 125	1300	1065	2400
6 MXV 50/1612	DN 125	DN 125	1334	1065	2400
6 MXV 50/1614	DN 125	DN 125	1403	1065	2400
6 MXV 50/1616	DN 125	DN 125	1472	1065	2400
6 MXV 65/3202	DN 200	DN 200	841	1180	2400
6 MXV 65/3203	DN 200	DN 200	947	1180	2400
6 MXV 65/3204	DN 200	DN 200	993	1180	2400
6 MXV 65/3205	DN 200	DN 200	1173	1180	2400
6 MXV 65/3206	DN 200	DN 200	1219	1180	2400
6 MXV 65/3207	DN 200	DN 200	1265	1180	2400
6 MXV 65/3208	DN 200	DN 200	1311	1180	2400
6 MXV 65/3209	DN 200	DN 200	1357	1180	2400
6 MXV 65/3210	DN 200	DN 200	1403	1180	2400
6 MXV 65/3212	DN 200	DN 200	1619	1180	2400
6 MXV 80/4801	DN 200	DN 200	845	1250	2400
6 MXV 80/4802	DN 200	DN 200	940	1250	2400
6 MXV 80/4803	DN 200	DN 200	1001	1250	2400
6 MXV 80/4804	DN 200	DN 200	1196	1250	2400
6 MXV 80/4805	DN 200	DN 200	1258	1250	2400
6 MXV 80/4806	DN 200	DN 200	1319	1250	2400
6 MXV 80/4807	DN 200	DN 200	1380	1250	2400
6 MXV 80/4808	DN 200	DN 200	1566	1250	2400

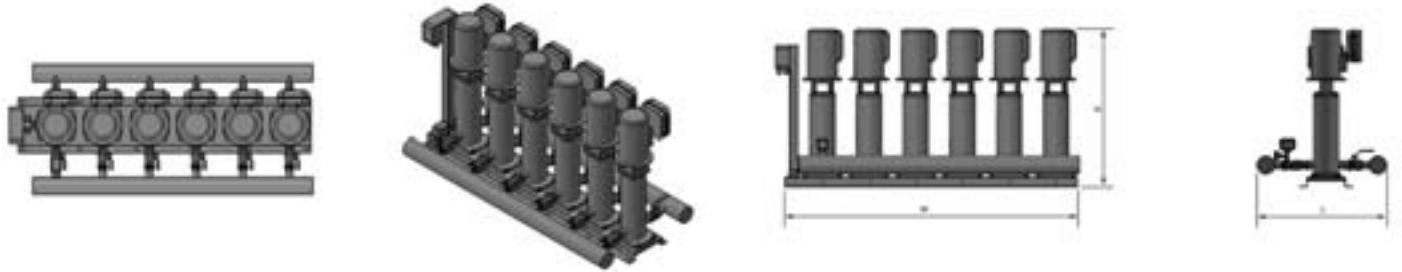
Dimensions of industrial boosters with six pump

Model	DNs	DNd	H	W	L
6 MXV 100/6501/1	350	350	1059	1365	2400
6 MXV 100/6501	350	350	1100	1365	2400
6 MXV 100/6502/2	350	350	1190	1365	2400
6 MXV 100/6502/1	350	350	1399	1365	2700
6 MXV 100/6502	350	350	1399	1365	2700
6 MXV 100/6503/2	350	350	2009	1365	2700
6 MXV 100/6503/1	350	350	2009	1365	2700
6 MXV 100/6503	350	350	2009	1365	2700
6 MXV 100/6504/2	350	350	1579	1365	2700
6 MXV 100/6504/1	350	350	1579	1365	2700
6 MXV 100/6504	350	350	1579	1365	2700
6 MXV 100/6505/2	350	350	1799	1365	3000
6 MXV 100/6505/1	350	350	1799	1365	3000
6 MXV 100/6505	350	350	1799	1365	3000
6 MXV 100/6506/2	350	350	1899	1365	3000
6 MXV 100/6506/1	350	350	1899	1365	3000
6 MXV 100/6506	350	350	1899	1365	3000
6 MXV 100/6507/2	350	350	1979	1365	3000
6 MXV 100/6507/1	350	350	1979	1365	3000
6 MXV 100/6507	350	350	2029	1365	3300
6 MXV 100/6508/2	350	350	2109	1365	3300
6 MXV 100/6508/1	350	350	2109	1365	3300
6 MXV 100/6508	350	350	2109	1365	3300
6 MXV 100/9001/1	350	350	1020	1365	2400
6 MXV 100/9001	350	350	1020	1365	2400
6 MXV 100/9002/2	350	350	1319	1365	2700
6 MXV 100/9002	350	350	1319	1365	2700
6 MXV 100/9003/2	350	350	1409	1365	2700
6 MXV 100/9003/2	350	350	1409	1365	2700
6 MXV 100/9004/2	350	350	1629	1365	3000
6 MXV 100/9004	350	350	1629	1365	3000
6 MXV 100/9005/2	350	350	1719	1365	3000
6 MXV 100/9005/2	350	350	1719	1365	3000
6 MXV 100/9006/2	350	350	1859	1365	3300
6 MXV 100/9006	350	350	1859	1365	3300
6 MXV 100/9007/2	350	350	2059	1365	3300



CALPEDA SPA

Via Roggia di Mezzo, 39 - 36050 Montorso Vicentino - Vicenza - Italy
Tel: + 39-0444 476 476 - **Fax:** + 39-0444 476 477 **e-mail:** info@calpeda.it

www.calpeda.com